

# Guidelines

## For Work Zone Designers



# Positive Protection



DEPARTMENT OF  
**Civil and  
Environmental Engineering**  
UNIVERSITY OF WISCONSIN-MADISON



## Technical Report Documentation Page

<b>1. Report No.</b>	<b>2. Government Accession No.</b>	<b>3. Recipient's Catalog No.</b>	
<b>4. Title and Subtitle</b> Guidelines for Work Zone Designers – Positive Protection		<b>5. Report Date</b> May 2019	
		<b>6. Performing Organization Code</b>	
<b>7. Author(s)</b> William Bremer, John W. Shaw, Madhav V. Chitturi, Andrea Bill, and David A. Noyce		<b>8. Performing Organization Report No.</b>	
<b>9. Performing Organization Name and Address</b> Traffic Operations & Safety Laboratory University of Wisconsin – Madison 1415 Engineering Drive #2205 Madison WI 53706		<b>10. Work Unit No. (TRAIS)</b>	
		<b>11. Contract or Grant No.</b> DTHF6114H00011	
<b>12. Sponsoring Organization Name and Address</b> Federal Highway Administration Office of Operations 1200 New Jersey Avenue SE Washington DC 20590		<b>13. Type of Report and Period Covered</b> Guidebook	
		<b>14. Sponsoring Agency Code</b>	
<b>15. Supplementary Notes</b> This material is based on work supported by the Federal Highway Administration. This publication does not constitute a national standard, specification or regulation.			
<b>16. Abstract</b> <p>Most State and many other transportation departments in the U.S. maintain roadway and/or work zone design manuals containing State specific regulations, policies, and design guidance for their designers and consultants to use. However, those manuals vary widely in the depth of coverage and the work zone design topics offered. National work zone design guidelines are lacking. This series of guidelines for work zone designers covers various work zone safety design topics for states, design manual decision makers, editors, and subject matter experts to develop or enhance their own guidance materials.</p> <p>“Guidelines for Work Zone Designers – Positive Protection” provides guidance covering the topic of positive protection in work zones and is not intended to be a stand-alone document for designing work zone traffic control plans. State, county, local, and tribal transportation agency subject matter experts, should use this material as reference material to augment their own work zone design policies and guidance.</p> <p>The material in this guide was gathered from existing State design manuals, considered as best state-of-the-practice by the authors and worthy of sharing with other states, and from state-of-the-art work zone safety and traffic management research documents developed by the Transportation Research Board, the FHWA and other institutions.</p>			
<b>17. Key Words</b> Work Zone Traffic Control, Traffic Control Plan Design, Positive Protection in Work Zones		<b>18. Distribution Statement</b> No restrictions.	
<b>19. Security Classification. (of this report)</b> Unclassified	<b>20. Security Classification. (of this page)</b> Unclassified	<b>21. No. of Pages</b> 84	<b>22. Price</b>

## Table of Contents

0. Foreword.....	1
1. Introduction .....	2
1.1. Objectives.....	4
1.2. The Safe System Approach.....	4
1.3. Advantages of Positive Protection .....	6
1.4. Disadvantages of Positive Protection.....	8
1.5. Positive Protection and the Work Zone Design Process.....	9
1.6. Alternatives to Providing Positive Protection .....	10
1.7. Common Mistakes and Problems with Positive Protection .....	10
2. Positive Protection Concepts.....	12
2.1. Crashworthiness .....	12
2.2. Barrier Deflection, Working Width, and Anchoring.....	14
2.3. Minimum Application Length, End Treatments, and Flaring.....	18
2.4. Transitions.....	23
2.5. Barrier Maintenance & Reusability.....	25
2.6. Drainage.....	26
2.7. Physically Constrained Sites .....	27
3. Types of Barrier Systems .....	28
3.1. Temporary Portable Concrete Barriers (TPCB).....	28
3.2. Portable Steel Barrier .....	29
3.3. Ballast Filled Polyethylene (Plastic) Barriers .....	30
3.4. Low Profile Concrete Barriers .....	34
3.5. Moveable Barriers .....	35
3.6. Mobile Work Zone Barriers .....	37
4. Barrier Accessories.....	39
4.1. Gates.....	39
4.2. Glare and Visibility-Reducing Screens.....	39
5. Related Technologies .....	44
5.1. Longitudinal Barricade Channelizers.....	44
5.2. Truck Mounted Attenuators .....	45
5.3. Vehicle Arresting Barrier (VAB) System .....	46
6. Mandatory Use of Barrier in High-Hazard Situations.....	47
7. Positive Protection Decision Making Guidance.....	49

7.1. Engineering Evaluation Process.....	49
7.2. Other Positive Protection Decision Making Guidance Processes.....	65
8. Selecting Barrier Types.....	67
8.1. Selection Criteria.....	69
8.2. Barrier Procurement and Specification.....	70
9. Review/Approval and Appeal Processes.....	72
9.1. Review & Approval Process.....	72
9.2. Appeal Process.....	72
9.3. Constructability and/or Quality Control Plan Reviews.....	72
10. Glossary of Terms.....	73
11. References.....	76

## List of Figures

Figure 1. Positive protection system.....	2
Figure 2. Barrier can provide protection against edge drops.....	2
Figure 3. Elements of the Safe System.....	5
Figure 4. An unforgiving driving environment.....	6
Figure 5. Risk of severe injury and death for pedestrians struck by a motor vehicle.....	7
Figure 6. Positive protection for motorized traffic and shielding workers.....	8
Figure 7. Barrier installation requires equipment, labor, and preparation.....	9
Figure 8. Barrier breached by truck impact.....	9
Figure 9. Barrier with missing and bent connectors.....	11
Figure 10. Structurally deficient barrier.....	11
Figure 11. Barrier incorrectly used without crashworthy end treatment.....	11
Figure 12. Successful crash test performed on proprietary J-J Hooks TPCB to MASH TL-3.....	14
Figure 13. Pocketing of a permanent steel beam guard adjacent to a rigid bridge parapet.....	15
Figure 14. Construction materials stockpiled next to barriers can alter vehicle deflections.....	15
Figure 15. Increasing the number of pavement anchors can reduce barrier deflection.....	18
Figure 16. Barriers incorrectly used to screen off an excavation.....	19
Figure 17. Barrier incorrectly used without crashworthy end treatment.....	19
Figure 18. Head-on crash test of a Chevrolet Lumina.....	20
Figure 19. Chevrolet Lumina test vehicle after impact.....	20
Figure 20. Sand-filled drums are a relatively portable crashworthy end treatment.....	20
Figure 21. Temporary portable concrete barrier with sand-filled drums as an end treatment.....	20
Figure 22. End treatment for a test level 3 water-filled portable barrier system.....	21
Figure 23. Water-filled portable end treatment for use with concrete barrier.....	21
Figure 24. Longitudinal space is necessary for barrier end treatments.....	21
Figure 25. The appropriate length of this type of impact attenuator depends on speed.....	21
Figure 26. Flared temporary portable concrete barrier system terminated outside of clear zone.....	22
Figure 27. Rigidity transition differences can reduce crashworthiness between barrier systems.....	23
Figure 28. Crashworthy transition from temporary to permanent barrier system.....	23
Figure 29. Sketch of a connection detail between permanent and temporary barriers.....	24
Figure 30. Upstream connection detail concept for overlapping barriers.....	24
Figure 31. Downstream connection detail concept for overlapping barriers.....	25
Figure 32. Structurally deficient barrier: spalling concrete.....	26
Figure 33. Physically damaged concrete barrier.....	26
Figure 34. TPCB generic design using steel pin-and-loops.....	28
Figure 35. TPCB J-J Hooks proprietary connecting load transfer system.....	28
Figure 36. Cross-section of WisDOT Temporary Precast 12' 6" long F-shape barrier.....	29
Figure 37. Internal view of J-J Hooks proprietary load transfer connection details.....	29
Figure 38. Installation of a steel barrier system.....	30
Figure 39. Steel barrier system in a bridge application.....	30
Figure 40. A considerable length of steel barrier can be transported on each truckload.....	30
Figure 41. Unloading steel barrier segments using a rough-terrain forklift.....	30
Figure 42. Test level 1 water-filled barrier system.....	31
Figure 43. Test level 1 water-filled plastic barrier system.....	31
Figure 44. Cross-section view of a NCHRP-350 TL-2 plastic barrier system.....	32

Figure 45. A NCHRP-350 TL-3 plastic barrier system with an external steel frame and water ballast .....	32
Figure 46. Texas DOT low-profile barrier application on suburban frontage road.....	35
Figure 47. Flared, sloped ramp end treatment for low-profile barrier system used by Texas.....	35
Figure 48. Florida DOT low-profile barrier application on a suburban two-lane undivided. ....	36
Figure 49. Connection detail on back-side for Florida DOT low-profile barrier. ....	36
Figure 50. Moveable barrier segments. ....	36
Figure 51. Barrier transfer machine. ....	36
Figure 52. Steel barrier with optional internal wheel kit to allow ease of moving.....	37
Figure 53. Repositioning a steel moveable barrier. ....	37
Figure 54. Workers shielded by Mobile Barriers MBT-1 .....	38
Figure 55. Mobile Barriers MBT-1.....	38
Figure 56. Barrier gates can facilitate access for emergency vehicles .....	39
Figure 57. Anti-glare paddles. ....	40
Figure 58. Fabric mesh glare screen on a thin-wall steel tubular frame. ....	40
Figure 59. Double reverse corrugated galvanized steel fabric glare screen. ....	40
Figure 60. Freestanding fencing with a visibility screen placed behind a barrier .....	40
Figure 61. Channelization of internal work area traffic.....	44
Figure 62. Channelization on low-speed urban street.....	44
Figure 63. Truck-Mounted Attenuator.....	45
Figure 64. Portable vehicle arresting system. ....	46
Figure 65. Abrupt pavement edge drops creates the potential for serious crashes. ....	52
Figure 66. Equation for Crash Reduction Benefits on Freeways .....	56
Figure 67. Equation for Crash Reduction Benefits on Two-Lane Rural Highways.....	56
Figure 68. Equation for Benefit/Cost Ratio.....	56
Figure 69. Relationships between speed reduction and casualty reduction (Nilsson 1981).....	63
Figure 70. Illustration of several frequently used design terms.....	73

## List of Tables

Table 1. MASH Test Levels .....	12
Table 2. Working widths for TL-3 NCHRP-350 and MASH concrete barrier systems .....	16
Table 3. Suggested Working Width Design Checklist. ....	16
Table 4. Examples of highway agency Work Zone Guideline Clear Distances .....	51
Table 5. Highway agency drop-off values for consideration of positive protection.....	52
Table 6. Examples of Factors to Consider in Positive Protection Decisions.....	62
Table 7. Overview of Positive Protection Systems . ....	68
Table 8. Example of method for calculating “high” volume. ....	74

## Cover & Back Page Photograph Sources

1. Federal Highway Administration
2. Easi-Set® Worldwide
3. Wisconsin Department of Transportation
4. Wisconsin Department of Transportation

## 0. Foreword

*Designing highways, bridges, and other transportation infrastructure is both a science and an art. Good design requires careful balancing of a wide range of technical, social, financial, and environmental considerations, many of which affect road user safety. To guide staff and consultants on agency design policies, highway and bridge design manuals are issued by many State Departments of Transportation (DOTs). Design manuals are also issued by some county, municipal, and tribal transportation departments and by other highway agencies such as tollway authorities.*

*This document is part of a series of prototypical work zone design guidelines developed by the Traffic Operations and Safety Laboratory (TOPS Lab) at the University of Wisconsin through a grant provided by the Federal Highway Administration (FHWA). The documents in this series are not intended for use directly by designers. Instead, they are intended to serve as a framework to assist agency technical editors in preparing relevant sections of their design manuals. It is anticipated that the material in this document will be augmented with agency-specific policy and procedural information. Highway agencies should adapt and modify the information in this document based on their own operational experiences, traffic conditions, terrain, climate, organizational structures, risk management policies, legislation, and case law.*

*Guidance included in this document represents recommended practices based on the author's expertise but does not constitute a national standard, policy, or regulation. However, this guidance may assist as a basis for agencies to develop their own policies for consideration of Positive Protection Devices in accordance with 23 CFR 630 Subpart k.*

*Reference in this document to any specific commercial products, processes, or services, or the use of any trade, firm, or corporation name is for the information and convenience of the reader, and does not constitute endorsement, recommendation, or favoring by FHWA or the authors.*

*Two font colors are used in this document to assist agency design manual editors in adapting the prototypical guideline material for their state-specific guidelines:*

**Black color normal text identifies narrative, text, and other materials ready for consideration for incorporation into agency-specific guidelines, with relatively little revision.**

*Italicized purple color text identifies commentary material and other issues that are likely to need modification to reflect agency-specific policies, organizational structures and choices, and require further considerations.*

*Note: Blue color is used to designate section heading numbers and titles in this Guide.*

## 1. Introduction

Many highway and bridge work zones require Temporary Traffic Control (TTC) to separate the work activity area from live traffic lanes, or to separate traffic streams moving in opposing directions. The Manual on Uniform Traffic Control Devices (MUTCD) [1] identifies several types of light-weight devices that can be used for this purpose, such as traffic cones, vertical panels, and drums. These lightweight devices help motorists navigate through work zones, but are not intended to protect workers from errant vehicles, nor can they prevent vehicles from leaving the travelled way. As shown in Figure 1 and Figure 2, temporary barrier systems and other positive protection devices are intended to address these safety functions. The MUTCD notes that, “temporary traffic barriers are not TTC devices in themselves; however, when placed in a position identical to a line of channelizing devices and marked and/or equipped with appropriate channelization features to provide guidance and warning both day and night, they serve as TTC devices.”

Compared to light-weight devices, positive protection systems provide greater physical protection for drivers and the workforce, but are considerably more expensive, require more time to set up and remove, and are generally more difficult to reposition as work progresses. As a result, it is often unclear which type of traffic control to deploy on a specific project.



Figure 1. Positive protection system.  
Source: FHWA



Figure 2. Barrier can provide protection against edge drops.  
Source: Wikimedia Commons/Michael Hicks

This document provides information to help guide decisions about when to use positive protection and what type of positive protection to specify. It includes an introduction to the topic of work zone positive protection, describes various types of temporary barrier systems and accessories currently approved for use in the United States, and provides a framework for the barrier selection process. A glossary of terminology related to positive protection is provided in Section 10.

Properly designed positive protection devices can help prevent motorized traffic from entering the work activity area, minimize injuries to vehicle occupants, and help shield workers, bicyclists, and pedestrians from motor vehicle intrusions. Typical uses include:

- Separating workers, pedestrians, or bicyclists from motorized traffic.
- Separating traffic streams travelling in two different directions.
- Separating high-speed freeway traffic from low-speed haul vehicles and other construction traffic.
- Separating high-speed traffic from slower, re-routed arterial traffic.
- Preventing traffic from reaching obstacles such as steep drop-offs and objects close to the travelled way.
- Shielding traffic from fixed obstacles, such as bridge false work.

This guideline uses a combination of policy-based criteria, engineering economic analysis, and engineering judgment to help guide decisions about the use of positive protection. Where possible, research-based analytical techniques are used to provide barrier use criteria that are as objective as possible. Some work zones have characteristics whose risk profiles cannot readily be quantified based on currently available research. In these cases, policy- or judgment based decisions are necessary. When setting such policies or making such decisions, it is important to recognize that transportation agency budgets are a finite resource: while it is certainly desirable to protect workers and the public from work zone crash risks, funds spent on temporary positive protection systems potentially affect the amount that can be spent to identify and address permanent safety hazards.

The process for assessing the need for positive protection includes three stages:

- 1. Identify Situations Warranting Mandatory Use of Barrier.** Agencies often identify a list of situations where failure to provide positive protection is likely to result in a significant risk of death or serious injury to road users and/or the workforce. Examples include bridges where permanent parapets have been removed and situations where there are steep drop-offs very close to the travelled way. In these situations, the designer may assume that the use of barrier is mandatory and specify its use in contractual documents without further justification or documentation. Additional discussion on possible situations is provided in Section 6 in this Guide.
- 2. Discretionary Use of Positive Protection Based on Engineering Study.** Many work zones require review and evaluation to compare the benefits and difficulties associated with the use of positive protection on a site-specific basis. Typical site conditions, including traffic volume, visibility, hazard severity, and work duration are used for conducting these evaluations. The recommended action should be based on careful engineering study and appropriately documented in the project file. Additional discussion on making these evaluations is provided in Section 7 in this Guide.
- 3. Review and Appeal Processes.** Most decisions about the use (or non-use) of barrier require a degree of engineering judgment. As a result, on occasion there will be disagreements about whether or not a barrier is appropriate for a particular site. A typical scenario of this might be a designer or project manager believing the use of positive protection is necessary, but a plan checker, supervisor, or manager feels that the expense of providing positive protection is not justified. More rarely, a situation could exist which meets the criteria for mandatory use of a barrier but with extenuating circumstances that possibly justify a different approach (such as extraordinarily low traffic volume). As

discussed in Section 9, a good practice is for agencies to establish a review and appeal process to resolve these disagreements promptly, consistently, and amicably.

*The authors recommend that each agency should establish a review process that staff can readily invoke if there is doubt or disagreement about the use (or non-use) of positive protection for a specific project. The process should be compatible with the agency's organizational structure and could be patterned after other design review and approval processes already used successfully by the agency, such as a design exception process. Implementation of an appeal process helps assure that decisions about where to use positive protection (and what type of positive protection to use) are based on the technical characteristics of each site and the agency's accumulated experience, and not solely on the judgment of a single individual.*

## **1.1. Objectives**

The objectives of this document are to:

- Provide a general overview discussion of positive protection.
- Describe barrier crashworthiness concepts and performance characteristics.
- Describe the design characteristics of various types of barrier systems.
- Discuss criteria for selecting appropriate work zone positive protection systems.
- Assist designers in determining whether an alternative to positive protection is appropriate for the site conditions.
- Provide definitions of terms associated with positive protection.

## **1.2. The Safe System Approach**

The Safe System approach is a relatively new way of thinking about the interaction of roads, road user behavior, vehicles, and speeds. It was published in 2008 as the result of a three-year cooperative effort by an international group of safety experts representing 22 countries [2]. The United States was represented in this effort by high-ranking officials from the Federal Highway Administration (FHWA), the Federal Motor Carrier Safety Administration (FMCSA), and the National Highway Traffic Safety Administration (NHTSA).

In the past, transportation safety efforts were often fragmented due to the difficulty of coordinating engineering, enforcement, and educational efforts overseen by various agencies and organizations. The Safe System approach is intended to overcome these difficulties. It states that improving roadway safety is a responsibility we all share as creators, managers, and users of the transportation system. To reduce casualties, we need safer roads and roadsides, safer vehicles, safer speeds, and safer road user behavior (Figure 3).



Figure 3. Elements of the Safe System.

Source: 2017 New Zealand Transport Agency©

In order to create a Safe System, it is necessary to recognize that all humans make errors and take risks—even road users who are well educated and law-abiding. Although it is probably not possible to prevent all crashes, the objective is to prevent crashes that result in death and serious injury. Roads, vehicles, road users, and speeds interact continuously. In a Safe System, crash survivability is enhanced by assuring that any failure in one part of the system is mitigated by the other elements of the system.

Positive protection is usually considered part of the Safer Roads & Roadsides element of a Safe System. As shown in Figure 4, without positive protection even a well-maintained roadway built to high standards can become an environment where minor driving mistakes can have dire consequences. Work zone positive protection can reduce the consequences of driver error, if it is correctly selected, designed, and installed. For example, barriers can reduce the likelihood that a driver who strays out of the lane will become involved in a fatal crash. Nevertheless, it is important to deploy positive protection judiciously so that the barriers themselves do not become a traffic hazard.

When discussing safety management strategies, it can be useful to distinguish hazards from risk. In a formal sense:

- A hazard is any source of potential damage, harm or adverse health effects to workers or road users.
- Risk is the probability of harm resulting from the hazard.

The level of risk will depend on factors such as how many people are exposed to the hazard and how severe their injuries could be. For example, an open manhole in a work zone is a hazard. The associated risk depends on where this hazard is located with respect to workers, pedestrians, and motorized traffic.



Figure 4. An unforgiving driving environment.  
Source : FHWA Report FHWA-SA-07-018

### 1.3. Advantages of Positive Protection

Work zones are complex environments that require high cognitive effort for the driver. The visual environment often includes large numbers of signs and other types of temporary traffic control devices. Traffic conditions in work zones often include lane closures, narrow lanes, lateral shifts, and rough pavement. Abrupt speed changes can occur during congested conditions. These complexities can amplify the consequences of common driving errors such as momentary inattention.

Motivations for providing positive protection include the following:

- **Worker Safety.** During the years, 2003 through 2010, an average of 19 highway workers per year were killed by traffic in U.S. work zones [3]. Properly deployed positive protection can reduce this risk by separating workers from traffic. Other major causes of worker fatalities include falling and being struck by equipment.
- **Shielding Pedestrians and Workers from Motorized Traffic.** The kinetic energy of a moving object is proportional to the square of its velocity. As illustrated in Figure 5, this results in a non-linear relationship between impact speed and the probability of death or serious injury for a pedestrian (or worker on foot) who is struck by a vehicle. U.S. research indicates that about 10% of pedestrians will die if struck by a motor vehicle at 23 mph. As speed increases, the risk of death increases sharply: about half of pedestrians struck at 42 mph will die because of blunt trauma injuries, and 90% will not survive an impact at 58 mph[4]. The use of positive protection can help reduce this risk, provided the configuration does not result in new risks such as pedestrians attempting to walk on or jump over the barrier.

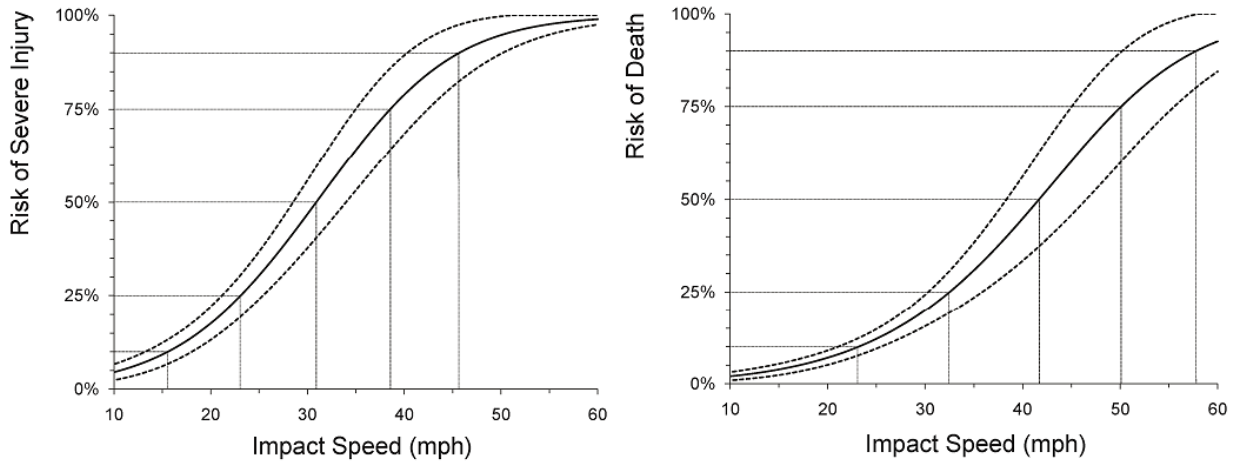

Figure 5. Risk of severe injury (left) and death (right) for pedestrians struck by a motor vehicle as a function of speed at impact based on a 1994-98 sample of 422 U.S. pedestrians aged 15+. The dotted lines represent the 95% statistical confidence intervals.

Source: AAA Foundation for Traffic Safety

- Driver Safety.** There was a 36% increase in work zone fatalities during the early 2000's compared to the latter half of the 1990's. This increase was largely attributed to the increase in highway reconstruction with traffic present within the work zone. After re-focusing national attention on work zone safety there was a 61% decrease in work zone fatalities from 2006-2012[5]. Several factors contributed to this improvement. Increased use of positive protection to shield drivers from drop-offs close to the travelled way, construction equipment as shown in Figure 6, and material storage was one contributing factor. Greater use of barriers to separate two-way traffic streams is also believed to have contributed to the improvement.
- Reduced Clear Zone.** In 2013, there were 270 fatal run-off-the-road single vehicle crashes in work zones[5]. Work operations often close highway shoulders or convert them into temporary driving lanes. This narrows the clear zone, making it more difficult for drivers to make an evasive maneuver, recover from a driving mistake, or compensate for a mechanical problem. Often the increased risk of driver casualties can be partially offset by providing positive protection to compensate for the reduced clear zone width.
- Protecting Construction Falsework and Other Temporary Facilities.** Positive protection can reduce the risk of vehicular traffic striking vulnerable facilities. This can avoid repair costs and in some cases, prevent casualties that would occur if the facilities were struck.



Figure 6. Positive protection for motorized traffic and shielding workers.

Source: Easi-Set® Worldwide

#### 1.4. Disadvantages of Positive Protection

While the use of positive protection has several benefits, there are also important counterpoints, trade-offs, and limitations. The disadvantages of positive protection can briefly be summarized as follows:

- The barrier itself can be an obstacle, especially if it is close to the travelled way. If unprotected, the blunt ends of concrete and steel barriers can be a significant hazard.
- Deployment of positive protection devices are costly and resource intensive.
- The process of installing and removing positive protection requires time, material, labor, and organization (Figure 7). These requirements sometimes make positive protection impractical, especially for small projects or emergency repairs.
- Barrier installation and removal often requires workers to be positioned close to live traffic.
- Compared to lightweight traffic control devices such as cones, vertical panels, drums, and similar devices, barriers are relatively difficult to reposition. This can make it difficult to take full advantage of newly completed work, adapt to fluctuations in traffic volume, or adjust to other changing conditions in the work zone.
- Barriers require lateral space to function correctly. It is sometimes difficult to obtain the necessary space, which includes the width of the barrier itself, shy distance in front of the barrier, and space behind the barrier sufficient for lateral deflection if it is struck by an errant vehicle.
- Barriers require longitudinal space to function correctly. This includes the area to be protected plus the length of crashworthy upstream and downstream end treatments. Lack of longitudinal space for end treatments sometimes makes the use of barrier infeasible, especially on roadways with closely spaced at-grade intersections.
- In work zones with limited width, using barrier sometimes results in narrow travel lanes, which can reduce traffic capacity and hasten the onset of congestion. Consequently, the safety benefits of barrier are sometimes partially offset by an increased risk of back-of-queue crashes at the approach to the congested area.

- In urban and suburban environments, the use of barriers sometimes increases pedestrian travel distances. In some cases, pedestrians are tempted to jump the barrier, resulting in an unexpected condition for motorists. Barriers can also attract risky behavior by children and teens, such as walking or playing on top of the barrier.
- Workers sometimes erroneously regard barriers as immovable and impenetrable, creating a false sense of security. In reality, when a barrier is struck its lateral deflection into the work area can be significant. In addition, most barrier systems are not designed to contain or redirect a tractor-trailer. For example, in a 2014 freeway work zone crash near Des Moines, Iowa, a portable concrete barrier shattered after being struck by a heavy truck (Figure 8)[6].



Figure 7. Barrier installation requires equipment, labor, and preparation.  
Source: Wikimedia Commons/BenAveling



Figure 8. Barrier breached by truck impact.  
Source: West Des Moines Police Department

## 1.5. Positive Protection and the Work Zone Design Process

As discussed in Sections 1.3 and 1.4, positive protection has benefits, limitations, and trade-offs. The decision to use (or not use) barriers usually affects other aspects of work zone design such as traffic management, construction vehicle ingress and egress, emergency vehicle access to work areas, traffic incident management, drainage, and project staging. Therefore, the decision about whether to provide positive protection (and which type to specify) requires careful consideration during the project development process. In most cases, the decision needs to be made fairly early in the work zone Transportation Management Planning (TMP) process. After a decision is made, a significant amount of re-design will probably be required if there are second thoughts about whether to use barrier.

Sections 2, 6, 7, and 8 of this document discuss the barrier decision-making process in detail. In brief, the process involves the following actions:

- Gathering work zone data such as geometric and traffic volume information.
- Identifying any high-risk situations that point toward the mandatory use of barrier.
- Determining work area clear zone widths and evaluating vertical edge drops.
- Evaluating the need to shield workers.
- Identifying potential exposure control measures that could eliminate need for positive protection.

- Selecting and specifying the most appropriate positive protection systems, if positive protection is justified by the previous steps.

## 1.6. Alternatives to Providing Positive Protection

Positive protection is not the preferred design alternative in every case. The Safe System approach (Figure 3) can serve as a framework when considering exposure control techniques as alternatives to positive protection. Techniques that influence the number and type of vehicles, road user behavior, speeds, or the roadway environment can potentially offset part of the risk associated with not using positive protection. Potential alternatives to positive protection include:

- Detouring all traffic to another route.
- Using ramp closures or other system configuration changes to redirect a significant portion of the traffic to other routes.
- Completing the work at a time when traffic volumes are low.
- Using speed reduction techniques such as pilot cars, pace vehicles, point-to-point automated speed enforcement, or intensive police presence.
- Using temporary backfill or wedging material to eliminate abrupt vertical drop-offs.
- Removing roadside obstacles to increase the available clear zone.
- Revising the construction method or work sequence to eliminate the need for positive protection.
- Combinations of the above.

In combination with these techniques, the use of closely spaced channelizing devices (and in some cases, extra signage) should be considered as part of an overall strategy to reduce the likelihood of a crash.

## 1.7. Common Mistakes and Problems with Positive Protection

A mid-1990s study identified common problems with temporary barrier systems based on work zone site audits. Issues included:

- Unprotected obstacles such as excessive vertical drop-offs.
- Incorrect barrier termination / improper end treatments.
- Approach angles that were too sharp for the barrier to function effectively.
- Installations that were too short to shield errant vehicles from the obstacle.
- Inadequate lateral clearance to workers or obstacles, for example insufficient distance for deflection of the barrier under vehicle impact.

Other documented problems include:

- Mismatch between temporary lane curvature and temporary barrier angle.
- Missing or bent barrier connectors (Figure 9).
- Damaged/deficient barrier sections (Figure 10).
- Barriers ending within clear zones without crashworthy end treatments (Figure 11).
- Barriers blocking roadway drainage.

- Failure to top-up water-filled barriers to compensate for evaporation.
- Misuse of non-crashworthy longitudinal channelizing devices as barriers.

Deficiencies such as those listed above can go unnoticed for a long time, especially if no vehicle happens to strike the barrier. Therefore, it is important for the designer to assure that the plans and specifications reflect good practice so that incorrect practices are not perpetuated by contractors or field engineering staff.



Figure 9. Barrier with missing and bent connectors.  
Source: John Shaw



Figure 10. Structurally deficient barrier.  
Source: John Shaw



Figure 11. Barrier incorrectly used without crashworthy end treatment.  
Source: John Shaw

## 2. Positive Protection Concepts

### 2.1. Crashworthiness

Since the purpose of a barrier is to improve safety in work zones by reducing and dissipating the kinetic energy of a vehicle that hits it, the barrier systems should be evaluated for crashworthiness. The crashworthiness objective is to reduce the risk and injury severity to those working within a project as well as to the vehicle occupants. A barrier system can be deemed crashworthy if crash testing under controlled conditions indicates that it can be struck without causing the test vehicle to sustain excessive damage, roll over, or go over/under the barrier (the barrier itself may be severely damaged). The system should also accept impact velocity and vehicle occupant accelerations.

Ideally, a barrier should redirect the vehicle away from the hazard within a narrow angle so that the vehicle follows the barrier and decelerates within a short distance. The goal is to keep decelerations well within human tolerance and comfort levels, and to avoid hindering the driver's recovery process or any necessary interventions by first responders.

U.S. crashworthiness test protocols for permanent and temporary roadside hardware were established by National Cooperative Highway Research (NCHRP) Report 350 in 1993[7]. They were subsequently updated by the AASHTO Manual for Assessing Safety Hardware (MASH) in 2009[8] and further revised by AASHTO in 2016[9]. The test vehicle types and speeds for the six MASH crash test levels are summarized in Table 1.

- The NCHRP Report 350 can be viewed on-line at [http://onlinepubs.trb.org/onlinepubs/nchrp/nchrp\\_rpt\\_350-a.pdf](http://onlinepubs.trb.org/onlinepubs/nchrp/nchrp_rpt_350-a.pdf)
- A preview containing selected pages from the 2009 AASHTO MASH can be found at <https://books.google.com/books?id=LV0mSYE9-S0C&lpg=PA11&ots=rLGtHE-UK3> and the table of contents and introduction for the 2016 AASHTO MASH at [https://bookstore.transportation.org/Item\\_details.aspx?id=2707](https://bookstore.transportation.org/Item_details.aspx?id=2707). Both of these complete documents can be purchased from the AASHTO bookstore at <https://bookstore.transportation.org/Home.aspx>

Table 1. MASH Test Levels

<b>MASH Test Level</b>	<b>Test Vehicle(s)</b>	<b>Test Speed</b>
TL-1	Automobile (2420 pounds) Pick-up Truck (5000 pounds)	31 mph
TL-2	Automobile (2420 pounds) Pick-up Truck (5000 pounds)	43 mph
TL-3	Automobile (2420 pounds) Pick-up Truck (5000 pounds)	62 mph
TL-4	Single unit truck (22,000 pounds)	56 mph
TL-5	Semi-tractor with van trailer (36,000 pounds)	50 mph
TL-6	Semi-tractor with tanker trailer (36,000 pounds)	50 mph

The AASHTO Roadside Design Guide recommends the use and design of longitudinal traffic barriers “should be based on an engineering analysis”[10]. The factors AASHTO recommends considering include “traffic volume, traffic operating speed, offset and duration that affect barrier needs within the work zones.” For example, a barrier successfully tested at TL-2 is generally sufficient for a suburban arterial with a 40 mph speed limit, but would not be appropriate for a freeway with a 70 mph speed limit. TL-3 systems should be used on all high-speed roadways. Although TL-3 hardware is tested at 62 mph, FHWA guidance allows TL-3 hardware to be used for highways with higher speed limits. TL-4 is recommended for locations with high volumes of heavy truck traffic, but currently only a few work zone products have been successfully tested to TL-4.

Another important recommendation in the AASHTO Roadside Design Guide and by the FHWA is the importance of conducting in-service performance reviews of roadside safety hardware, including work zone barriers. These tests cannot account for all the variables and situations the hardware will be subjected to in the field. This recommendation promotes gaining a better understanding on the actual safety performance under all conditions.

Changes are occurring for work zone hardware and crash testing criteria. In December 2015, AASHTO and FHWA signed an “AASHTO/FHWA Joint Implementation Agreement for the AASHTO Manual for Assessing Safety Hardware, 2016[11].” The agreement phases in the use of only MASH-tested hardware, including work zone equipment. Among the provisions in the agreement are the following statements: “Temporary work zone devices, including portable barriers, manufactured after December 31, 2019, must have been tested to the 2016 edition of MASH [8]. Such devices manufactured on or before this date, and successfully tested to NCHRP Report 350 or the 2009 edition of MASH may continue to be used throughout their normal service life”[11]

In the past, NCHRP-350 and MASH 2009 crash test criteria have both been used by manufacturers and researchers to evaluate safety hardware. FHWA also provided a service of reviewing crash testing results to determine eligibility of the devices in meeting the testing criteria. However, in May 2017 FHWA changed their process for issuing letters; letters are no longer issued for safety hardware crash tested using NCHRP 350 procedures, or to products that have not been successfully crash tested to the full suite of recommended tests as described in AASHTO MASH. The eligibility letters are not a requirement to use a product on a federal-aid project. States, manufacturers, and researchers are under no obligation to submit crash test information to the FHWA requesting an eligibility determination.

At the time of publication, the FHWA is maintaining a list of MASH crash tested safety hardware products, as well as archived NCHRP-350 crash tested hardware, (accessible at [https://safety.fhwa.dot.gov/roadway\\_dept/countermeasures/reduce\\_crash\\_severity](https://safety.fhwa.dot.gov/roadway_dept/countermeasures/reduce_crash_severity)) as a service to States, manufacturers, and researchers. To use the FHWA list for finding temporary barriers that have been submitted in the past, select “Longitudinal Barriers and Miscellaneous Items.” Then select whether you are interested in finding “MASH 2009 edition”, “MASH” for only 2016 edition devices, or “All” for both MASH 2009 and MASH 2016 tested devices, and then search the list of devices based on the date of the FHWA determination letter, manufacturer name,

and/or device description. There is also a link to the archived NCHRP-350 devices from this website.



Figure 12. Successful crash test performed on proprietary J-J Hooks TPCB to MASH TL-3 crash test criteria.

Source: Easi-Set® Worldwide

## 2.2. Barrier Deflection, Working Width, and Anchoring

**Deflection.** When temporary work zone barriers are struck, the system will deflect laterally. The amount of deflection depends on several factors such as the speed and weight of the impacting vehicle, the angle of impact, the weight of the barrier sections, the method used to link barrier sections, and if the barrier is anchored to the roadway surface (Figure 15). Near the end of a barrier run, the distance from the free end to the point of impact can greatly affect deflection distance. For example, typical portable concrete barriers can move up to five to six feet if struck near the middle of a run, and will deflect even more if struck near an unanchored end.

**Working Width.** When selecting a barrier system and laying out the work zone, it is important for designers to compare the design deflection distance with the available lateral space. The “working width” is the distance between the traffic face of the barrier before impact and the farthest lateral position of any major part of the barrier after impact with a test vehicle. The term “working width” was introduced in MASH in 2009[8]. For products tested under the older NCHRP 350 criteria, the working width can be approximated by adding the total barrier width to the reported maximum deflection distance.



Figure 13. Pocketing of a permanent steel beam guard adjacent to a rigid bridge parapet.

Source: FHWA.



Figure 14. Construction materials stockpiled next to barriers can alter vehicle deflections.

Source: Wikimedia Commons/Michael Hicks

Gradual transitioning the stiffness in barrier systems is required to prevent undesirable crash dynamics. Therefore, contract specifications should prohibit large fixed objects, stockpiled materials and parking large construction equipment (Figure 14) in the barrier working width distance. These objects can prevent temporary barrier systems from deflecting properly. However, tolerable risk is normally accepted and necessary to allow equipment to occupy the working width for short periods during construction operations. A good understanding in the design process of the working width that will be available is important. If working width space will be limited for lengthy periods to accommodate work operations or need to keep fixed objects near the temporary barrier, consider designing a reduced working width crash tested barrier system. Generally, these reduced working width systems require more time to install and/or are more expensive, and typically involve anchoring and/or the barrier devices are more massive. If a reduced working width is only needed for a portion of the total barrier length, using a crash-tested transition system is appropriate. An example of material stockpiled within the working width of a temporary, non-anchored barrier system is shown in Figure 14.

When vehicles strike a barrier where too much barrier deflection (vehicle penetration) is closely followed by too little or no deflection, undesirable gravitational force levels (g-forces) will result in greater bodily injury to vehicle occupants due to the sudden stopping or too rapid deceleration in the vehicle trajectory. This sudden increase in g-forces commonly causes the barrier appear to “snag” the vehicles, and this is often referred to as “pocketing” (Figure 13). This sudden change in vehicle trajectory or speed can also increase the risk of a vehicle rollover. Appropriate transition design for temporary barrier systems is provided in Section 2.4.

Table 2 provides the working width for several crash tested approved barrier systems. Working widths for other systems can usually be found or estimated using information in research reports, manufacturer literature, or the FHWA product acceptance letter for the relevant system (see Section 3.1 of this document for information about how to retrieve acceptance letters). A suggested working width design checklist is provided in Table 3.

Table 2. Example working widths for several TL-3 NCHRP-350 and MASH concrete barrier systems

System Description	FHWA Identifying Code #	Working Width	Comments
Midwest Free Standing F-Shaped Temporary Concrete Barrier System	B-215	8.5 feet	Individual 12'6" long barriers, with steel pin and loop connections
J-J Hooks Temporary Concrete Barrier	B-52	6.25 feet	Individual 12' long barriers, with steel J hooks cast in each barrier end for connecting units.
New York Free Standing NJ Shaped portable concrete barriers	B-94	6.2 feet	Individual 20' long barriers, with steel I-shaped pins into key way for connecting barrier units.
New York State Temporary Concrete Barrier w/ Box Beam Stiffener	B-239	4.3 feet	Same barrier as B-94 plus 12' long 6"x 6" steel box beams attached to back of barrier across each joint
J-J Hook Temporary Concrete Barrier with Deflection Reducing Retrofit	B-251	2.23 feet	Same barrier as B-52 plus 2 steel retrofit plates (6" wide x 22" x 1/2") attached to barrier face contour and 26" long x 1 1/2" diameter steel pins through retrofit plates and drilled into pavement.
Kansas Anchored F-Shaped Temporary Concrete Barrier System	B-122	1.75 feet	Same barrier as B-215 plus 3 anchor bolts (12' long by 1 1/4" diameter) and nuts (3"x3"x 1/2" thick) epoxied through front of each barrier base into concrete pavement.

Table 3. Suggested Working Width Design Checklist.

<ul style="list-style-type: none"> <li><input type="checkbox"/> Determine the available deflection distances in all areas where positive protection will be specified.</li> <li><input type="checkbox"/> Identify appropriate barrier systems for the available deflection distances. Determine whether each system can be free standing or requires a deflection reduction technique such as anchoring.</li> <li><input type="checkbox"/> If anchoring is being considered, verify that the existing roadway surface or bridge deck is structurally adequate to hold the anchors securely and can be installed without damaging permanent infrastructure.</li> <li><input type="checkbox"/> Select and specify approved crashworthy systems, including transition details and deflection reduction techniques (if required).</li> <li><input type="checkbox"/> Prepare contractual provisions for each barrier system that will be used on the project, including stipulations regarding the use (or non-use) of anchoring. Include contractual provisions to assure that anchor holes are promptly backfilled with approved grouting material after the barrier is removed.</li> <li><input type="checkbox"/> Include contractual language stipulating that the deflection space kept clear of stockpiled materials, parked heavy equipment, and other large/heavy objects.</li> </ul>
--

- |   |
|---|
| <ul style="list-style-type: none"><li>❑ Consider allowing the contractor to propose alternative barrier systems, subject to agency approval.</li><li>❑ Verify that field inspectors and construction engineering staff are aware of the system design requirements and remind them to enforce restrictions on material storage and heavy equipment parking.</li></ul> |
|---|

**Anchoring and Other Deflection-Reduction Techniques.** Deflection reduction techniques are available for certain types of barriers. These techniques are frequently used in the following situations:

- Bridge decks where temporary barrier serves as a temporary bridge parapet.
- Edge-drop protection where the barrier will be placed close to a trench or drop-off.
- Restricted-width situations where long-term equipment or material storage is planned within the deflection distance.
- Sites where reduced deflection is expected to improve worker safety.
- 

The traditional approach to anchoring has been to attach the barrier to the roadway surface (or bridge deck) using large anchor bolts. This requires drilling several large holes in the pavement or deck, increases cost, and makes it quite time-consuming to reposition the barrier. Great care is necessary to assure that drilling an anchor hole does not damage structural elements such as bridge tensioning cables. After the barrier is removed, anchor holes should be properly grouted to avoid long-term structural damage caused by infiltration of water, salt, and other de-icing chemicals.

When anchor bolts are used, the anchoring surface should be structurally adequate. For example, a deteriorated bridge deck might not be strong enough to retain the anchor bolts in the event of a crash.

In 2014, the University of Nebraska reported the development of retrofit joint stiffening mechanisms that do not require anchor bolts but can reduce the deflection by almost 50% compared to free-standing barriers. Such systems could be particularly advantageous for bridge projects, since they avoid the need to drill into the bridge deck. [12]

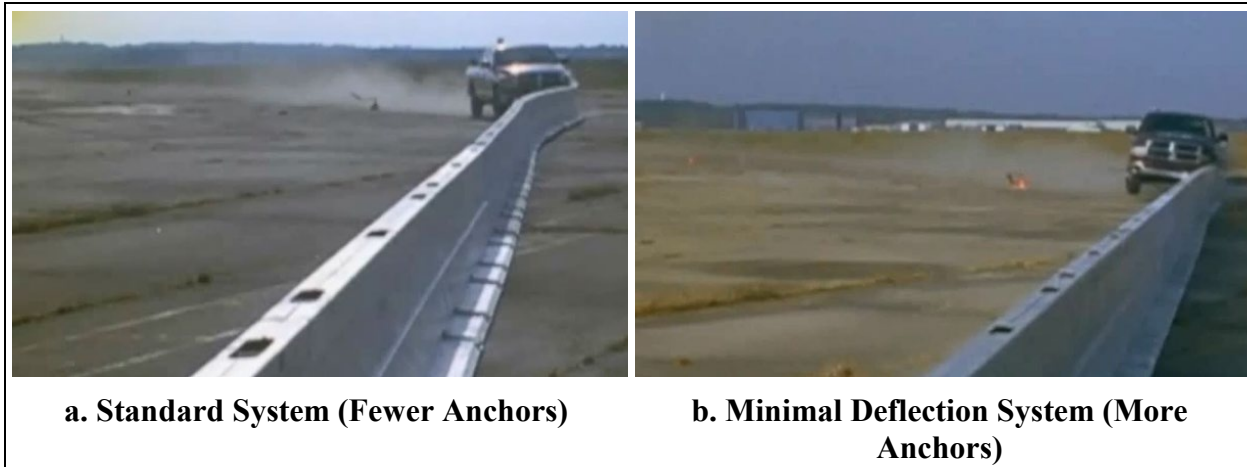

Figure 15. Same barrier, different anchoring system. In these two successful crash tests, increasing the number of pavement anchors substantially reduced barrier deflection but the test vehicle momentarily lost ground contact.

Source : <http://www.hillandsmith.com/zoneguard/>

Anchoring or stiffening affects the crash dynamics of the barrier system (Figure 15). Because of increased rigidity, errant vehicles are more likely to be redirected back into the traffic stream, which increases the risk of secondary collisions.

Transition systems typically require an anchor layout that is specific to the barrier system that is being used. It is important that all anchoring details conform to the approved crash-tested designs. Therefore, all relevant anchoring details (including anchoring transitions) should be included in the project plans. Additional discussion and design information can be found in Section 9.2.1.2.16 of the AASHTO Roadside Design Guide[10].

Anchoring systems vary by barrier type. For Temporary Portable Concrete Barriers (TPCB), the Roadside Design Guide identifies three NCHRP 350 compliant anchoring designs that use steel pins or bolts to connect the barriers to a bridge deck or road surface:

- California K-Rail Portable Concrete Barrier for Semi-Permanent Installations (developed by Caltrans).
- New Jersey shaped TPCB (developed by Texas DOT).
- F-shaped TPCB (developed by the Midwest Roadside Safety Facility).

### 2.3. Minimum Application Length, End Treatments, and Flaring

**Minimum Application Length.** If a barrier installation is too short, it will not have enough mass to perform correctly if struck by an errant vehicle. The minimum application length is product-specific; it depends on the rigidity and mass of the barrier system and is determined through crash testing. The minimum application length for each barrier system may be found in its crash test report. A minimum length check is important for all barrier system designs, especially lighter-weight barriers with large deflection distances.

Most temporary work zone barrier systems are freestanding: they are “attached” to the pavement surface only by their own weight. Since resistance to lateral deflection is achieved through friction, freestanding barriers will deflect a considerable distance if struck near the end of a run. Therefore, it is necessary to extend the barrier run upstream and downstream of the area that requires shielding, unless barrier ends are anchored to the surface using crashed tested techniques.

Designers should consult manufacturer literature, relevant FHWA product acceptance letters, and Section 5.6.4 of the Roadside Design Guide to determine the minimum application length for the barrier systems they specify. *A type of Temporary Portable Concrete Barrier (TPCB) widely used in many Midwestern states, shown in Figure 34, is 12.5 feet long and each unit weighs approximately 5400 pounds. Field experience and testing with the Midwestern barrier indicate that to prevent excessive lateral deflection into the area of need, barrier runs should extend at least 100 feet (8 sections) upstream and downstream of the area that is being shielded. If barrier runs are started or ended before the length of need is fully established, then anchoring barriers per crash testing procedures at the terminal barrier ends should be considered.*

**Avoid Blunt Ends.** Barriers with blunt ends can be a serious safety concern (Figure 16 to Figure 19). A crashworthy end treatment should be specified for all barrier systems that terminate within the clear zone. As discussed in further detail in the AASHTO *Roadside Design Guide* (RDG), acceptable termination methods include:

- A crash-tested impact attenuation system (crash cushion) (see RDG sections 8.4 and 9.3).
- Flaring the barrier to a point beyond the clear zone, such as shown in Figure 26.
- Connecting to an existing crashworthy barrier to avoid exposing the end of the temporary barrier.
- The use of sloped end treatments is restricted. Section 9.2.2 of the RDG provides guidance about their use.



Figure 16. Barriers incorrectly used to screen off an excavation.  
Source: Wisconsin DOT



Figure 17. Barrier incorrectly used without crashworthy end treatment.  
Source: John Shaw



Figure 18. Head-on crash test of a Chevrolet Lumina and a concrete barrier (without impact attenuator).  
Source: DeChant Consulting Services



Figure 19. Chevrolet Lumina test vehicle after impact.  
Source: DeChant Consulting Services

**Impact Attenuators.** Impact attenuators (also called crash cushions) are designed to dissipate kinetic energy in the event of a head-on collision with the end of the barrier. Arrays of drums filled with dry sand (Figure 20) are a relatively low-cost impact attenuator system. Several proprietary crash cushion systems are available. Some systems are intended primarily for permanent applications, while others (Figure 23) are also suitable for work zone applications. As with barriers, the attenuator test level should be consistent with the expected operating speeds. Test level three (TL-3) devices are typically used for high-speed roadways.



Figure 20. Sand-filled drums are a relatively portable crashworthy end treatment.  
Source: Wikimedia Commons/jpg



Figure 21. Temporary portable concrete barrier with sand-filled drums as an end treatment on a 2-lane rural highway project.  
Source: Wikimedia Commons/



Figure 22. End treatment for a test level 3 water-filled portable barrier system.  
Source: Energy Absorption Systems, Inc.



Figure 23. Water-filled portable end treatment for use with concrete barrier.  
Source: Energy Absorption Systems, Inc.

The available longitudinal and lateral space are important design considerations when selecting and specifying impact attenuators (Figure 24). For example, the U.S. distributor of the modular system shown in Figure 25 recommends using three modules at sites where the anticipated impact speed is 30 mph; this increases to 11 modules for a 70 mph impact[13]. These space requirements can be a significant factor when designing work zone access (ramps, side streets, driveways, and emergency access points). For work zones on suburban arterials, water-filled barriers sometimes fit the available longitudinal space more easily than concrete or steel barriers.



Figure 24. Longitudinal space is necessary for barrier end treatments such as the yellow segments  
Source: WikiMedia Commons



Figure 25. The appropriate length of this type of impact attenuator depends on the traffic speed[13].  
Source: Wikimedia Commons/JPG

Additional impact attenuator design issues that should be verified by the designer include:

- Impact attenuators are primarily designed to be struck head-on. The angle of the attenuator should be consistent with the most-likely approach angle for an errant vehicle. At features such as temporary lane shifts and crossovers, this could differ from the approach angle under non-construction conditions.
- Contraflow operations are situations where traffic is re-routed to the opposite of a roadway. In these situations, attenuators might be required to protect fixed objects that do not ordinarily face toward traffic (note the attenuator on the downstream end of the

barrier shown in Figure 24, which perhaps indicates that opposite-direction operation was anticipated during some stage of the construction).

- The minimum barrier length downstream of the attenuator should be consistent with the manufacturer's recommendations.
- Some attenuator systems require anchoring. In these cases, appropriate surfaces should be present, or if not, temporary anchoring pads should be constructed to assure that the system layout is consistent with manufacturer's recommendations and the conditions for which it was certified.
- Symbolic representation of barrier end treatments in computer aided design cell libraries or standard drawings are frequently used to simplify the development of plans, but these symbols may not accurately reflect the actual physical size of these features on to-scale drawings.
- Therefore, the angle of the attenuator relative to traffic, the existence of adequate pavement surface for anchorage, and space required for the attenuator units should be closely examined and verified in the design phase to prevent potential change orders.

**Flaring.** As shown in Figure 26, it is sometimes possible to avoid the need for an impact attenuator by extending the barrier run upstream and gradually angling it to a point beyond the clear zone; this is called flaring.

- Section 5.6.3 of the RDG provides flare rates for permanent barriers, which vary based on design speed. These flare rates are desirable for locations where the barrier is expected to remain for extended duration (such as an entire construction season or longer).
- Due to space limitations and/or steep side slopes, it is not always possible to achieve the permanent-installation flare rates. Section 9.2.1.2 of the RDG suggests that higher flare rates (from 4:1 to 8:1) may be cost effective in these situations.
- For urban streets with high traffic volumes, speeds are typically lower and impact angles are usually higher than for rural highways. The RDG reports that a flare rate of 5:1 to 6:1 may be slightly more favorable in these situations.



Figure 26. Flared temporary portable concrete barrier system terminated outside of clear zone.

Source: Wisconsin DOT

The document editor may wish to insert additional agency-specific details about end treatments and flare rates here. Several state specific examples are described below:

- Wisconsin DOT's Facilities Development Manual (FDM) includes a set of Standard Detail Drawings titled *Crash Cushion/Sand Barrel Array and Other Temporary Barrier Layout Details*. The document discusses how to introduce and terminate Temporary Portable Concrete Barrier (TPCB). It also provides guidance on appropriate separation distances between barrier runs, and when to anchor TPCB. The drawings can be found in FDM Chapter 16, Section 5, Standard Detail Drawing's 14B-1a thru e) at: <https://wisconsindot.gov/rdwy/sdd/sd-14b08.pdf#sd14b8>.
- Florida DOT's Office of Design has also prepared a set of detailed design standards for starting and ending TPCB's. The drawings can be found at: [https://fdotwww.blob.core.windows.net/sitefinity/docs/default-source/design/standardplans/2020/idx/102-100.pdf?sfvrsn=b1904648\\_2](https://fdotwww.blob.core.windows.net/sitefinity/docs/default-source/design/standardplans/2020/idx/102-100.pdf?sfvrsn=b1904648_2)

## 2.4. Transitions

The transitions between temporary and permanent barrier systems are an important design detail. Pocketing, explained in Section 2.2, can occur if an errant vehicle strikes an area where a rigid barrier meets a more flexible one. Abrupt changes in rigidity (Figure 27) should be avoided. To reduce the risk of snagging an errant vehicle (which can cause it to spin or roll), the connection should also be free of abrupt lateral protrusions. Research analysis and crash testing has identified a limited number of crashworthy transitions between permanent and temporary barrier systems. *A thorough review and analysis of available crashworthy transitions should be conducted when developing State specific standard details for the types of permanent and temporary barrier systems in use.*



Figure 27. The crashworthiness of this connection between temporary and permanent barrier systems is doubtful due to differences in rigidity, which will result in likely heavy vehicle “pocketing” for high-speed impacts.  
Source: Wikimedia Commons/Poudou99



Figure 28. Crashworthy transition from temporary to permanent barrier system using three beam rail.

Source: Midwest Roadside Safety Facility-Univ. Nebraska-Lincoln

**Transitioning TPCB to Permanent Concrete Barrier.** There are two crashworthy methods for providing strength continuity between temporary portable concrete and permanent concrete barrier systems and minimize pocketing to impacting vehicles:

- Figure 28 shows a crashworthy design for transitioning TPCB to permanent concrete barrier. Two nested 12-gauge thrie beam rails are attached on both the front and rear sides of the connected systems, as conceptually shown in Figure 29. Alternatively, front and rear 10 gauge thrie beam rails can be used, but rail elements in this size are not readily available in most markets [14].
- An alternative method for use with any type of temporary and permanent barriers is to overlap the two barrier systems. Research has shown the overlap by approximately eight TPCB barrier units, approximately 100 feet at each end, will greatly reduce the risk of pocketing if a vehicle strikes the barrier near the beginning of the overlap area[15]. If the overlapping temporary barrier is in front of the permanent barrier, an attenuator is necessary to reduce crash severity in case of an end-on hit at the temporary barrier’s upstream end (Figure 30). No attenuator is necessary if the overlapping temporary barrier is behind the permanent barrier (Figure 31).

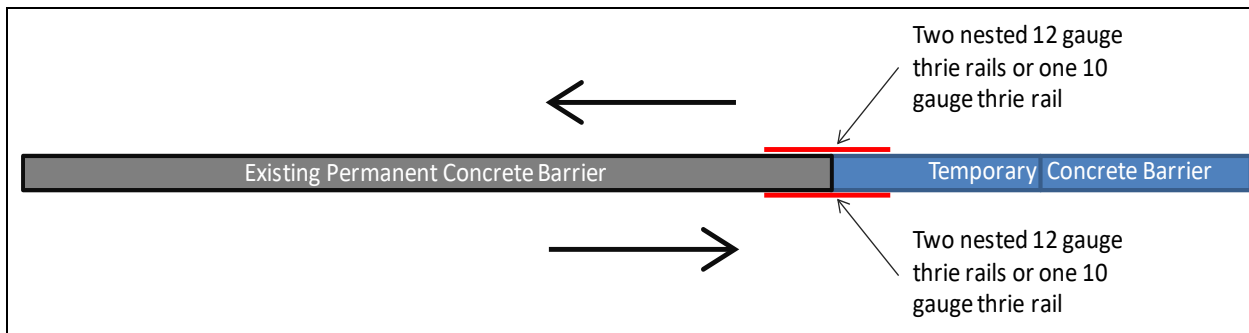

Figure 29. Conceptual sketch of a connection detail for permanent and temporary barriers using thrie rail (not to scale).

Source: TOPS Lab

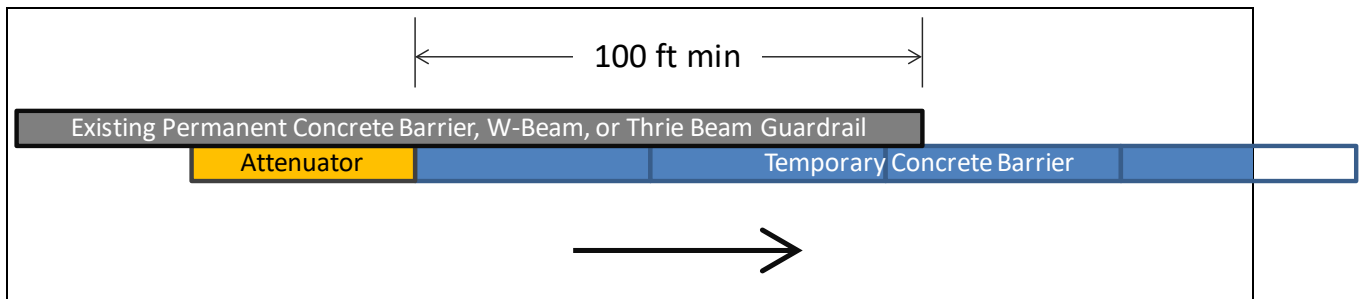

Figure 30. Upstream connection detail concept for overlapping barriers (not to scale).

Source: TOPS Lab

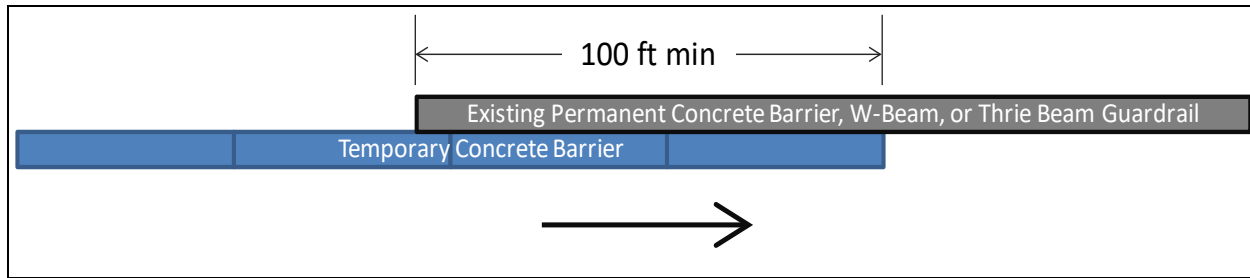

Figure 31. Downstream connection detail concept for overlapping barriers (not to scale). Note when lateral space is available it is desirable to provide a gap between the two barrier systems in order to minimize potential pocketing or snagging (see discussion in Section 2.2) of the temporary barrier at the end of the permanent barrier.

Source: TOPS Lab

**Transitioning TPCB to Permanent Steel Guardrail.** Research has been conducted to analyze the challenges to develop crashworthy transitions between TPCB and permanent steel guardrail. Based on this research, a crashworthy TPCB to a permanent steel Midwest Guardrail System (MGS) has been developed [16]. This crashworthy system consists of a standard MGS that overlaps a series of F-shape TPCB segments that approaches the MGS at a 15:1 flare rate. The approved system has some uniquely designed block out holders and a specialized W-beam end shoe-mounting bracket to connect the systems. *If the agency has developed a standard detail drawing for this situation, mention it here.*

*A thorough review and analysis of the latest available research on crashworthy transitions should be conducted when developing State specific standard details for transitioning between their TPCB system(s) and their permanent steel guardrail system(s).*

**Transitioning from freestanding temporary barrier to fully anchored temporary barrier.** In situations where fully anchored temporary barriers are necessary to minimize deflections and freestanding barriers are needed upstream, a crash tested transition anchoring pattern should be specified between the two temporary barrier systems. Crashworthy transition testing has been completed on asphalt and concrete surfaces and approved in accordance with NCHRP 350 and MASH criteria[17][18]. *A thorough review and analysis of the latest available research on crashworthy transitions from freestanding TPCB system should be conducted when developing State specific standard details.*

## 2.5. Barrier Maintenance & Reusability

The crashworthiness of a barrier can be compromised if it is structurally inadequate, damaged, or incorrectly installed. Work zone barrier systems are typically designed to be re-usable. Barriers are usually the property of the contractor (or a traffic control subcontractor), and this creates an economic incentive to re-use them as many times as possible. Therefore, the contractual documents should include criteria for rejection and/or replacement of barriers that are not in serviceable condition.

Structurally deficient barriers (Figure 32) should not be used. Barrier sections that become damaged or deficient during construction (Figure 33) should promptly be replaced, and the contractual documents should stipulate a maximum amount of time allowed for replacement.

Rejection/replacement criteria should be established in advance, especially if the agency or contractor is using a new type of barrier for the first time.



Figure 32. Structurally deficient barrier: spalling concrete.  
Source: Wisconsin DOT



Figure 33. Physically damaged concrete barrier.  
Source: John Shaw

Special monitoring of barrier condition could be appropriate if the barrier serves a particularly critical function, for example if it separates two-way high-speed traffic or the shy distance between the barrier and live traffic is narrow. In such situations, the designer might want to consider requiring frequent inspection of barrier condition and position, along with rapid response to correct deficiencies. If an out-of-position barrier impedes the safe flow of traffic, it will probably be necessary to close lanes until the situation can be corrected.

## 2.6. Drainage

Temporary barriers can impede the flow of drainage water. During rain events and periods of melting snow, temporary barriers can act as dams, which could result in ponding water into traffic lanes causing vehicles to hydroplane. Most barrier designs include holes, slots, or scuppers to facilitate drainage (these openings sometimes double as lifting points). Some water will also flow through the narrow space between barrier sections. The hydraulic capacity of these openings is not always sufficient, especially in climates that are prone to sudden heavy rainfall; at locations where the openings are prone to clogging by leaves, debris, mud, snow, or ice; or at sites with heavy runoff from work activities such as wet-curing concrete. Runoff from adjoining properties is sometimes also a contributing factor in preventing all of the water from escaping the pavement.

Some drainage issues can be resolved by substituting a barrier type that has more hydraulic capacity, or by widening the shoulder to provide a temporary water storage area. In other cases, supplemental temporary drainage systems could be required. This should be considered as part of the overall plan for work site stormwater management and erosion control.

When water ponding occurs, it is often at the bottom of a hill or on the low side of a horizontal curve, potentially with limited visibility for approaching road users. Appropriate MUTCD-compliant advance warning signage should be considered. Typical messages include the “SLIPPERY WHEN WET” and “ROAD MAY FLOOD.” The MUTCD also allows the use of the message “WET PVMT” on a portable changeable message sign.

## 2.7. Physically Constrained Sites

Installing barriers in accordance with recommended layout dimensions can be difficult in work zones where physical space is limited, such as urban streets with closely spaced intersections. The designer should treat restricted sites with special attention. In some cases, exposure control measures can be used to eliminate the need for barriers, as discussed in Section 1.6 of this document.

- If exposure control measures will not eliminate the need for barrier, section 9.2.1.2.17 of the RDG provides suggested risk-reduction criteria.
- NCHRP Report 358 *Recommended Practices for Use of Traffic Barrier and Control Treatments for Restricted Work Zones* provides additional guidance on this topic. This 1994 publication is available for purchase at: <http://www.trb.org/publications/pages/262.aspx>.

### 3. Types of Barrier Systems

#### 3.1. Temporary Portable Concrete Barriers (TPCB)

The AASHTO *Roadside Design Guide* (RDG) [10] describes Temporary Portable Concrete Barriers (TPCB) as “free-standing, precast, concrete segments, 8 feet to 30 feet in length, with built-in connecting devices.” TPCB is currently the most commonly used type of positive protection barrier. Several types of crash-tested TCPBs are available, including both proprietary design and generic designs (Figure 34 and Figure 35). Most systems have been tested to Test Level 3 and a few at TL-4. Although TL-4 barriers cost more, they have greater resistance to truck impacts and are usually taller than TL-3 barriers, which usually provides better screening of glare from oncoming headlights.



Figure 34. TPCB generic design steel pin-and-loops used for connecting adjoining F-shape concrete sections. Anchor point locations for anchoring to roadways are visible, as well as lifting holes through the barriers, are visible in this photo.

Source: Midwest Roadside Safety Facility- Univ. of Neb



Figure 35. TPCB J-J Hooks proprietary connecting load transfer system used for connecting F-shape concrete sections. Self-aligning section is lowered into place allowing connection to “hook” together with contiguous sections.

Source: Easi-Set® Worldwide

The weight of typical TPCBs varies from 390 to 720 pounds per lineal foot depending on the height, cross-section, geometry, and amount of steel reinforcement. When considering which design to specify, greater mass has both positive and negative attributes:

- When struck, a heavier system will generate more friction between the bottom of the barrier and the underlying surface, which tends to limit barrier movement and overturning.
- A heavier system will need larger equipment and possibly more labor for installation and removal. It might also be more difficult to move the barrier during construction. Significant resources are necessary for hauling precast TPCB units to/from the project site; a heavier system will need more truckloads and thus greater trucking costs. A heavier system could also require more deployment time, potentially resulting in greater traffic impacts and more worker exposure during installation.

Several TBCB connecting systems have been accepted by FHWA through the crash testing process. Some connection systems are proprietary, (e.g. Figure 37) while others are in the public domain, (e.g. Figure 36.)

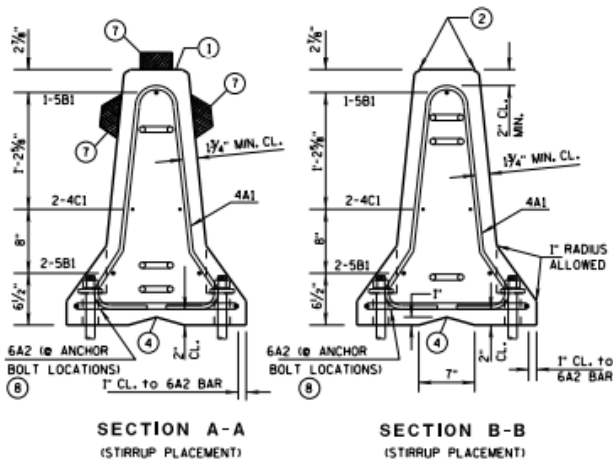

Figure 36. Cross-section of WisDOT Temporary Precast 12' 6" long F-shape concrete barrier. Note, location of three optional delineators are shown near top of left drawing. Source: WisDOT S.D.D. 14B 7-15a

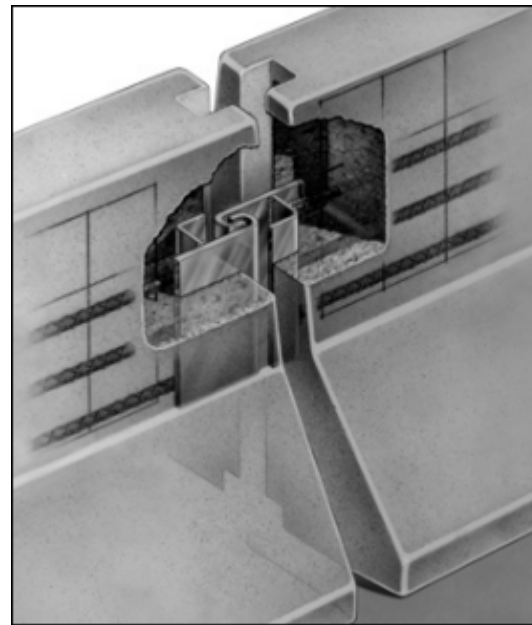

Figure 37. Internal view of J-J Hooks proprietary load transfer connection details. Source: Easi-Set® Worldwide

### 3.2. Portable Steel Barrier

**Description.** Portable steel barrier is a longitudinal barrier system comprised of galvanized steel panels. Segment lengths and joining systems vary by manufacturer. Several systems have been successfully crash-tested under NCHRP 350 or MASH criteria, including at least one product that meets NCHRP 350 TL-4 criteria. Although most of the systems are proprietary, a low-deflection non-proprietary system fabricated from steel H-beams was developed (primarily for bridge projects) by Iowa DOT and the University of Nebraska.

Individual segment lengths vary by manufacturer, but are typically in the range of 26 to 50 feet. Typical weights for individual segments are 3000 to 3300 pounds. Although substantially lighter than Temporary Portable Concrete Barrier (TPCB), most steel systems have lateral deflection characteristics similar to TPCB.



Figure 38. Installation of a steel barrier system.

Source : <http://www.hillandsmith.com/zoneguard/>



Figure 39. Steel barrier system in a bridge application.

Source: Lindsay Corp.

Steel offers the following potential advantages in comparison to temporary concrete barrier:

- Reduced trucking costs. Up to 750 feet of steel barrier can be transported on each truck, as shown in Figure 40 and Figure 41. By comparison, for a temporary concrete barrier weighing 500 pounds per lineal foot, only 160 feet of barrier can be transported on each 80,000-pound capacity truck.
- Faster installation time. A crew can install 1000 to 1500 feet of barrier per hour according to manufacturer literature, (e.g. Figure 38).
- Reduced equipment and labor is typically needed for installation and removal.
- Relatively easy to move and reconfigure. This can be advantageous for short-duration projects or sites requiring frequent traffic control staging changes (e.g. Figure 39).

Although steel barrier products are relatively new, they are available for rental in some markets, allowing agencies and contractors to try this device without a major capital investment.



Figure 40. A considerable length of steel barrier can be transported on each truckload.

Source : Lindsay Corp.



Figure 41. Unloading steel barrier segments using a rough-terrain forklift.

Source : <http://www.hillandsmith.com/zoneguard/>

### 3.3. Ballast Filled Polyethylene (Plastic) Barriers

**Description.** Polyethylene (commonly referred to as plastic) barriers are a highly portable longitudinal barrier system. The barriers are comprised of segmental polyethylene shells, filled

with a ballast material at the work site. Besides the outer plastic shell and ballast material, many of these proprietary barriers have internal or external steel frames, or internal steel cables to improve strength requirements for higher impact speeds. The type and amount of steel frames will vary on the manufacturer for the different test levels. Typically, the segments use steel pins to connect the multiple segments together to make the desired length. Besides specifying the appropriate test level barrier for the work site conditions, designers should include individual manufacturer's installation instructions. *Because some water ballasted barriers and barricade channelizers are similar in appearance, the FHWA recommends each unit or module be labeled to indicate limitations on use.*

These systems are easy to deploy because the empty shells are generally light enough to be lifted manually by two workers. Water-ballasted applications are the most common, since the barrier can be drained and moved to another location at the completion of the project.

The weight of water is approximately 62 pounds per cubic foot. The bulk densities of dry sand and reinforced concrete are approximately 1.6, and 2.4, respectively compared to water. Therefore, when filled with water a plastic barrier weighs about 40% as much as a concrete barrier with a comparable cross-section, and a sand-filled barrier has about 67% of its concrete counterpart's weight.



Figure 42. A test level 1 water-filled barrier system used to separate bicyclists from low speed urban street traffic.

Source: Traffix Devices



Figure 43. A test level 1 water-filled plastic barrier system used to separate pedestrians from urban street traffic.

Source: Wikimedia Commons with photo editing by TOPS Lab

**Applications.** Appropriate applications for plastic barriers depend on the crash test level to which they have been certified:

- **Empty plastic shells** do not provide positive protection and have no re-directive capability. As discussed in Section 5.1, they are typically used as a MUTCD longitudinal channelizing device, for internal worksite traffic management, and for pedestrian traffic management on low-speed urban streets.
- **Test Level 1** identifies devices that have been successfully tested at 31 mph. They are suitable for low-speed roadways such as urban streets. For example, Figure 43 shows an urban street where water-filled barrier was used as a separator when pedestrians were temporarily redirected onto part of the street.

- **Test Level 2** identifies devices that have been successfully tested at 43 mph. They are suitable for medium-speed applications such as projects on urban and suburban arterials, as shown in Figure 44.
- **Test Level 3** identifies devices that have been successfully tested at 62 mph. This test level is necessary for high-speed applications. As shown in Figure 45, an external steel reinforcement frame is used by this manufacturer. Other manufacturers have approved TL-3 systems that use internal steel reinforcement and plastic pedestals to elevate the plastic shell and ballast material.



Figure 44. Cross-section view of a NCHRP-350 TL-2 plastic barrier system with internal steel frame for use in urban application (note water ballast material is placed within the shell at the work zone site for the barrier to be considered fully operational.)

Source: Energy Absorption Systems, Inc. (A Trinity Industries Co.)



Figure 45. A NCHRP-350 TL-3 plastic barrier system with an external steel frame and water ballast on a tollway application.

Source: Trinity Highway Products, LLC

Some (but not all) plastic barrier systems are designed to serve as their own end treatments, eliminating the need for a separate impact attenuator. This characteristic might be helpful in situations with limited longitudinal space. Specific manufacturer's FHWA crash test determination letter should be used to make this determination.

Deflection is a significant design consideration for plastic barriers. Deflection is typically in the range of 6 to 25 feet, depending on the speed and vehicle weight. It is not feasible to anchor plastic barriers to the roadway surface, so this distance cannot be reduced. Therefore, plastic barriers should only be used at sites where the expected lateral deflection can be accommodated. Since the lateral deflections are higher than TPCB, barrier crashes tend to be less severe to vehicle occupants.

During winter construction in cold climates, the designer should specify sodium chloride (salt) or an environmentally friendly antifreeze added to the liquid to prevent the ballast from freezing into a solid mass.

Water-filled barriers can be particularly useful in the following applications:

- Short-duration projects or maintenance work where concrete or steel barrier deployment is undesirable due to time constraints or cost.
- Rapid response to roadside obstacles left by crashes, storms, rockslides, earthquakes, etc.
- Locations where the use of heavy equipment for lifting concrete or steel barrier is impractical.
- Physically constrained areas, such as intersections and railroad crossings, where a system can serve as its own end treatment is advantageous.
- Urban and suburban roadways with typical running speeds of 45 mph or lower, where a Test Level 1 or 2 system is sufficient.

Although sand is difficult to remove from the barrier, sand-ballasted barriers may be suitable for niche applications such as semi-permanent or long-term applications.

A negative aspect for plastic barrier systems is their maintenance after a vehicle strike. The plastic shell usually splits or shatters upon impact, spilling the ballast material (water or sand), potentially onto traffic lanes, requiring lane closure to remove the spilled material. Another negative aspect that designers need to consider is whether the barrier will be used during freezing weather. If the water or sand in the barrier becomes frozen, the system may not function properly unless installed following the barrier manufacturer's recommendations and specifications. Depending on whether the added mass is allowed to freeze, or whether an anti-freeze material is added to the mass material to prevent freezing, barrier removal, movement, or cleanup after a vehicle strike may be challenge for the contractor.

In most cases, water-filled barrier removal is straightforward: the water is simply drained onto the ground. In rare cases, it could be necessary to specify that the ballast liquid is transported offsite for disposal, which would increase removal time and cost. If ordinary draining will not be permitted, this should be specified in the contract along with any environmental restrictions related to salt or antifreeze disposal.

**Color.** Many manufacturers offer plastic barriers in two or more colors, typically orange and white. In some cases, a contrasting color can help draw attention to the ends of the barrier. The use of an extended series of alternating color barrier segments is *not* recommended in high-speed driving environments. This is because visual sciences research suggests that attention grabbing, high-contrast changes in the minor parts of a scene can cause people to overlook more important changes in the center of the scene, a phenomenon called “change blindness”.

### 3.4. Low Profile Concrete Barriers

Texas and Florida have developed low-profile portable concrete barrier systems, which are approximately 20 inches or less in height for temporary applications, as shown in Figure 46 and Figure 48. These systems were patented, and considered as proprietary systems by FHWA when their TL-2 crash test approval letters were issued. Therefore, the systems are used primarily on low- and medium-speed roadways.

*Both systems have special royalty arrangements, and users should discuss with the patent holders prior to using either system in their standards or projects. In addition, FHWA regulations should be reviewed and followed if patented devices will be used on federal-aid funded projects.*

The types of projects that may benefit most from using low-profile barriers are urban street widening and underground utility work that involve deep excavations and drop-offs. Low-profile barriers offer the following potential advantages over standard-height 32 inch temporary barrier systems[19]:

- Greater visibility for line of sight of approaching traffic for motorist stopped on side streets and driveways.
- Better defined workspace for workers, drivers, and pedestrians.
- Typically, fewer channelization devices are needed, and channelization devices that are used may be installed on top of the barrier, which should reduce the chance of being struck.
- Low barrier deflection distances when struck by errant vehicles.
- Constructability benefits due to ease of installation and removal compared to heavier barrier systems.

The standard length for the individual units are 12 feet for the Florida system and 20 feet for the Texas system. Each system has a unique method for connecting the units together. The Florida connection method is shown in Figure 49.

Texas and Florida each have crash tested approved end terminals for their respective system. Both systems use a sloping ramp end terminal that allows an errant vehicle to ride up and onto the barrier. The Texas end terminal is shown in Figure 47.



Figure 46. Low-profile barrier application on suburban frontage road (Texas DOT low profile barrier system).

Source: Photo reproduced with the permission of the American Traffic Safety Services Association (ATSSA) and photo edited by TOPS Lab



Figure 47. Flared, sloped ramp end treatment for low-profile barrier system used by Texas DOT.

Source: Photo reproduced with the permission of the American Traffic Safety Services Association (ATSSA)

### 3.5. Moveable Barriers

**Description.** Moveable barriers are proprietary systems designed to allow frequent lateral repositioning. Typical applications include:

- Creating a reversible lane. For example, if the work zone has only enough width for three lanes, two lanes could be used for inbound commuter traffic in the morning and the barrier could be shifted to provide two outbound lanes in the afternoon.
- Adjusting the width of the work area by time of day. For example, two lanes could be open to traffic during daytime hours, and at night, the barrier could be shifted to provide one traffic lane (and more contractor workspace).
- Increasing the lateral buffer space between work operations and live traffic during peak hours.

**Examples.** One type of moveable barrier system is comprised of short concrete segments. As shown in Figure 50, it consists of a chain of 39-inch (1 meter) segments connected by hinges. Each segment has a T-shaped top that allows it to be mechanically lifted and shifted laterally up to 18 feet by a proprietary self-propelled barrier transfer vehicle (one version of the vehicle is shown in Figure 51). The manufacturer claims that the transfer speed is up to 5 mph (12 minutes per mile of barrier). When crashworthy barrier end protection is required, the T-top impact attenuator shown in Figure 25 is compatible with the system. Space for safe storage of the transfer vehicle is necessary at both ends of the work area.



Figure 48. Low-profile barrier application on a suburban two-lane undivided roadway (Florida DOT low-profile barrier system).

Source: Photo reproduced with the permission of the American Traffic Safety Services Association (ATSSA)



Figure 49. Connection detail on back-side for Florida DOT low-profile barrier system.

Source: Photo reproduced with the permission of the American Traffic Safety Services Association (ATSSA)



Figure 50. Moveable barrier segments.

Source: Wikimedia Commons



Figure 51. Barrier transfer machine.

Source: Lindsay Corporation

At least two steel barrier systems are available with optional wheel kits to facilitate repositioning. One example is shown in Figure 52; it uses manual or pneumatic jacks to lower the wheels and lift the barrier off the pavement for ease of movement. As shown in Figure 53, a pick-up truck or skid-steer loader equipped with a special attachment is then used to push the barrier to the new location, and the wheels are then retracted. Repositioning takes longer than the system that uses a specialty transfer machine, but it is still much faster than re-setting typical concrete barrier.

Water-ballasted plastic barriers are also relatively easy to reposition, though this requires draining and refilling the barrier.

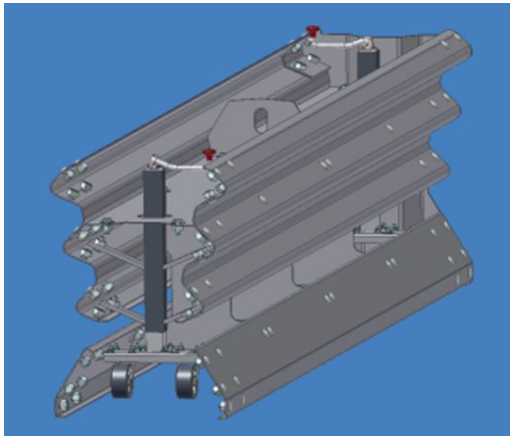

Figure 52. Steel barrier with optional internal wheel kit to allow ease of moving.

Source: Trinity Highway Products, LLC



Figure 53. Repositioning a steel moveable barrier.

Source : Lindsay Corporation

**Applications.** Moveable barrier systems are primarily applicable to situations where it is appropriate to change the work zone road space allocation at different times of the day, either by switching the direction of the middle lane or by giving the contractor extra working space during off-peak hours. Under these conditions, the system has the potential to optimize work zone capacity, reduce construction time, reduce the number of construction stages, and perhaps reduce construction costs.

Moveable barrier rental can be costly. An engineering cost effectiveness study should be conducted before a mobile barrier system is specified. The purpose of the study is to determine whether the costs of deploying the system are proportional to the anticipated reductions in road user delay or construction costs. Typically, these systems can show greater benefits on very high volume, long-term projects.

### 3.6. Mobile Work Zone Barriers

Mobile barrier systems are semi-tractor trucks with portable work zone barriers incorporated into the trailers. The barrier system provides a physical and visual wall to shield workers from adjoining traffic lane(s) and protect motorists who may depart from their traffic lane at a worksite. The system also uses a truck-mounted attenuator attached to the rear of the trailer to protect workers and traffic approaching from the rear. The portable work zone barriers are primarily used for short length and/or short-duration work zone construction and maintenance operations done under traffic. Typical work operations may include precast pavement slab replacement, pavement patching, shoulder repair, guardrail, bridge rail, barrier terminal installations and repairs, and bridge deck and joint repairs. A significant advantage for using a mobile barrier system besides safety is the ability to rapidly deploy and remove the system from the work site, which reduces the time a lane(s) is closed to traffic.

The only mobile barrier system commercially available in the U.S. is the proprietary Mobile Barriers MBT-1 system developed by Mobile Barriers, LLC[20], as shown in Figure 54. The MBT-1 consists of a 5-foot tall smooth steel wall to shield the work activity area from the side, combined with an impact attenuator and a changeable message sign at the rear, and is transported by a semi-tractor truck. Wall sections can be added to increase the length of the work area from 42 feet to 102 feet. The device can be reconfigured for left or right side of road placement by swapping the positions of the semi-tractor and the rear wheels. The system comes equipped with integral electrical power and work illumination equipment that further supports rapid work commencement, as shown in Figure 55. The unit can be outfitted with a supplemental lifting crane for assisting with work operations. The system has been crash tested successfully for side impact conditions using MASH TL-3 (62 mph) criteria.

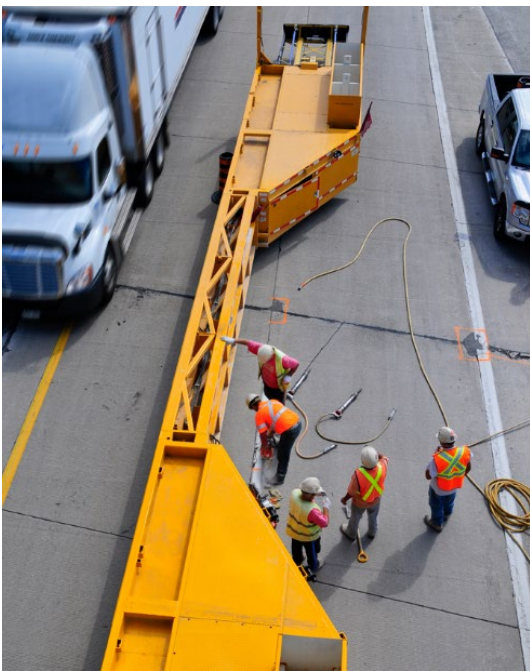

Figure 54. Workers shielded by Mobile Barriers MBT-1

Source : Mobile Barriers, LLC



Figure 55. Mobile Barriers MBT-1.

Source : Mobile Barriers, LLC

## 4. Barrier Accessories

### 4.1. Gates

At least two manufacturers offer kits that convert their steel barriers into a gate (Figure 56). One use of these gates is for bringing heavy equipment such as cranes and excavators into the work area. Another potential application is to provide additional access points for incident management during construction.



Figure 56. Barrier gates can facilitate access for emergency vehicles and delivery of heavy equipment to the jobsite.

Source: Lindsay Corporation

### 4.2. Glare and Visibility-Reducing Screens

**Description.** Glare screens and visibility-reducing screens (also called gawk screens) can be attached to the top or back of some types of barriers (Figure 57 to Figure 59). Alternatively, if there is traffic on only one side of the barrier, freestanding fence panels with visibility screens can be placed behind it (Figure 60). In some cases, a tall barrier is used to avoid the need for a separate glare screen.

There are three main work zone applications for screening:

- Reducing headlight glare from opposing traffic (as a glare screen).
- Blocking driver views of bright lights beyond the highway (as a glare screen).
- Limiting drivers' ability to see distracting work activities (as a gawk screen).

Several types of glare and gawk screening products have been developed:

- **Vertical paddles** resemble a Venetian blind (Figure 57). Various heights are available, typically 24, 36, or 48 inches. They are lightweight with a gap between adjoining paddles. For proper headlight glare control the horizontal angle of the paddles should be

adjusted based on the curvature of the roadway. Because of the wide space between paddles, they are not suitable for blocking grit or road debris.

- **Screening panels** are continuous across the top of the barrier (Figure 58 to Figure 59). They typically extend about 24 inches above the barrier. Solid panels can reduce the amount of grit and road debris that enters the work area. In some cases, they can also help deter trespassing on limited-access facilities.



Figure 57. Anti-glare paddles.  
Source: Beilharz Road Equipment Systems



Figure 58. Fabric mesh glare screen on a thin-wall steel tubular frame. To reduce vehicle-snagging risks, the panels attach to the backside of the barrier.

Source: New Zealand Transport Agency



Figure 59. Double reverse corrugated galvanized steel fabric glare screen.

Source: TRANSPRO Industries, Inc.



Figure 60. Freestanding fencing with a visibility screen could be placed behind a barrier on the non-traffic side.

Source: Fence Factory Rentals

**Applications.** The AASHTO Roadside Design Guide (Section 9.5.1) and MUTCD (Section 6F.88) provide guidance on beneficial applications of glare and gawk screens. The most widespread use is to limit headlight glare during contraflow operations (where it is necessary to run two-way traffic on one side of a normally divided freeway), particularly if there is no overhead highway lighting. Another application is to reduce glare when the roadway elevation is being changed, particularly if one traffic direction's headlights will be at an elevation that is close to eye level for the opposite direction. A related use is to reduce glare in the driving lanes by blocking the view of floodlights used to illuminate night work activities, stockpiles, or batch plants if the glare cannot be eliminated by adjusting the direction or angle of the floodlights.

Some examples of locations that potentially justify using glare screens or paddles include:

- Near crossovers and other sites with counter-directional (contraflow) traffic.
- In advance and through horizontal curves.
- In advance of lane tapers adjacent to the work area.
- Near extended-duration, fixed-locations where work activities are in close to motorized traffic, such as bridge deck construction.

Factors to be considered when determining whether to specify the use of a screening system include:

- Night traffic volumes.
- Prevalence of night highway crashes.
- Highway geometry
  - Lane width.
  - Median width.
  - Distance to opposing traffic.
  - Vertical curvature.
  - Horizontal curvature.
- Proximity of workers to live traffic.
- Extent of work area distractions.
- Direction and intensity of roadway lighting and ambient light from adjoining properties.

In some cases, screens can reduce delineation washout (loss of visibility of pavement markings due to glare), help prevent work zone crashes, and reduce public complaints. In many cases, such issues are only brought to the agency's attention after construction has already started, but ongoing communication with field engineers can help designers identify potential problem areas in advance so that appropriate screening treatments can be included in plans and bid documents.

**Crashworthiness.** Currently there are no U.S. national crash test criteria (MASH standards) for screens or other objects mounted on top of barriers. The Roadside Design Guide emphasizes the importance of screens that “will not penetrate the passenger compartment or present an undue risk to workers or other traffic” and “perform in a predictable manner when struck.” Nevertheless, these characteristics have been difficult for designers to assess in the absence of crash test results. Instead, designers usually rely on in-service performance information.

Although barriers and screens are often supplied by different manufacturers, from a safety performance perspective they should be considered together as a system. Any crash tests performed with screens are only applicable to the specific barrier used in the test, and normally only evaluate the performance of the barrier and screen combination for occupants of the errant vehicle, not the effects of the resulting debris to workers or pedestrians near the crash site. Therefore, designers may want to review in-service performance regarding past debris issues, if workers and bystanders will always be in the area where the screens are used.

In the absence of crash testing standards, designers should consider the following principles for selecting and using glare and gawk screening products:

- The taller the barrier and the more it deflects, the less likely it is that the screens will be struck by an errant vehicle riding up into the “intrusion zone” on top of the barrier.
- Screens that attach to the barrier using adhesives, small bolts, or thin brackets are less likely to pose a concern than those using steel pipe, large bolts, or heavy brackets.
- Screen frames should not be attached directly to the front (traffic side) of a barrier, as this would create a snagging hazard if the barrier were struck by an errant vehicle. If there is traffic on only one side of the barrier, the screen can be attached to the back. If there is traffic on both sides, the screen should be attached to the top of the barrier.
- If struck, lightweight screens such as small plastic paddles, foam panels, fabric mesh, or expanded steel mesh are less likely to pose a concern than plywood or other heavy materials.
- If wood products are allowed, consider specifying material that is as thin and weak as possible to reduce the likelihood of serious injury to vehicle occupants. Lightweight corrugated plastic panels should be considered as an alternative to wood.
- Tubular steel frames, if used, should be fabricated from thin-wall tubing (such as EMT electrical conduit). Rigid steel pipe (such as water pipe) should not be used. Connections should be welded, not bolted. Steel tubing bends and frame corners should have an outside radius of 4 inches or more; sharp corners should be avoided [21]. Alternatively, frames could be assembled from plastic drainpipe with glued connections.
- For roadside applications, installing stand-alone screens behind the barriers will reduce the risk of an errant vehicle striking the screens. The preferred distance between the back of the barrier and the stand-alone screen is generally 2 to 4 feet.

**Other Design Considerations.** The following should be considered when specifying screening devices:

- Screen height should be sufficient to block glare and/or views of the work activity area, while maintaining the visibility of traffic signs and areas where there could be conflicting traffic. A height of 4 to 6 feet above the pavement is usually satisfactory. It might be necessary to omit some of the screen panels so that signs and conflict areas remain visible to road users.
- Fabric panels should be securely attached to their frames to prevent wind tattering.
- To avoid driver distraction, all screens used on high-speed roadways should be the same color. An inconspicuous screen color such as dark green can help keep the driver’s attention focused on the road.
- Graffiti can occur on barriers and screens, especially in urban areas. Graffiti makers are attracted to a blank canvas. In low-speed urban street applications, printing subtle decorative graphics such as a tree or leaf motif on screens sometimes helps deter graffiti. The presence of graffiti tends to attract more graffiti, so contractual provisions should be established to assure that any unauthorized marks are removed promptly using methods that will not damage the screen.

- Screens should be kept entirely free of large contractor or agency logos and other advertising. Small labels or stencils to identify the owner of the screen may be permissible and useful.

## 5. Related Technologies

### 5.1. Longitudinal Barricade Channelizers

Lightweight longitudinal barricade channelizers such as the ones shown in Figure 61 often have a physical shape that is similar to a barrier, but they are not designed to provide positive protection and have very limited or no re-directive capabilities. Longitudinal channelizers are mainly used for directing pedestrians and bicyclists through work zones, and to deter pedestrian access to excavations. They can also be used to guide motor vehicle traffic along low-speed facilities, as shown in Figure 62, or to direct the internal circulation of construction vehicles within work activity areas. Channelizers may or may not have a water-filled ballast, depending on their purpose. The water filled barricade channelizers may serve to support screens, fences, or sign supports.



Figure 61. Channelization of internal work area traffic.

Source : Wikimedia Commons



Figure 62. Channelization on low-speed urban street

Source:: Wikimedia Commons/Jean Housen

When preparing traffic control plans, designers should ensure that both barriers and lightweight channelization devices are used for their intended functions. In simplistic terms:

- Longitudinal barricade channelizers are only suitable for low-speed pedestrian and bicyclist traffic management adjacent to low speed urban streets. However, longitudinal barricade channelizers should be crashworthy. Work zone crashworthiness testing is done to assure there is no occupant compartment intrusion, excessive vehicle deceleration, or vehicle instability.
- TL-1 and TL-2 water-filled plastic barriers are mainly suitable for low and medium-speed motor vehicle traffic management on urban and suburban streets.
- TL-3 and TL-4 steel and concrete barriers are suitable for managing traffic on freeways and other high-speed limited-access roadways.

In contrast to most rigid barriers and some non-rigid systems, channelizers usually act as their own crashworthy end treatments. This can be advantageous for traffic management on low-speed urban streets with closely spaced intersections and driveways.

## 5.2. Truck Mounted Attenuators

A shadow vehicle is a truck or trailer used to shield workers or work equipment from errant vehicles, especially during mobile work operations. The back of each shadow vehicle is often equipped with a Truck Mounted Attenuator (TMA) (Figure 63). TMAs are energy-absorbing devices designed to reduce impact severity. They primarily provide protection for occupants of the impacting vehicle (occupants of the shadow vehicle are protected to a lesser extent). The combination of a shadow vehicle and a TMA helps shield workers from rear-end collisions, but the work operation remains vulnerable to side impacts. As explained in more detail in Section 2.1 of this document, a list of FHWA-accepted TMAs can be found on the FHWA website.



Figure 63. Truck-Mounted Attenuator.

Source: Wikimedia Commons/Ingolfson

Shadow vehicles equipped with TMAs should be considered for worker protection during installation of temporary barrier systems and other work zone traffic control. Other frequent applications of shadow vehicles with TMAs include:

- Protecting work areas that move continuously (or frequently), such as paint striping and pothole patching.
- Shielding workers engaged in short-duration and intermediate-duration work operations.

The AASHTO Roadside Design Guide (RDG) provides application guidelines for shadow vehicles and TMAs. Chapter 6 of the MUTCD includes numerous Typical Applications that recommend shadow vehicles.

To be fully effective, the shadow vehicle needs to be correctly positioned. The MUTCD distinguishes between the activity area (where work is occurring) and the upstream longitudinal buffer space. The longitudinal buffer is a safety space upstream of the activity area and kept entirely free of equipment, vehicles, and material. Although shadow vehicles are positioned within the activity area, they need to lag back far enough to provide adequate roll-ahead distance if the shadow vehicle is struck from behind. The roll-ahead distance should be noted on relevant design drawings. Section 9.3.2.2 and Table 9.4 of the RDG provide guidance on these positioning and spacing details.

### 5.3. Vehicle Arresting Barrier (VAB) System

A proprietary portable netting energy-absorbing system, referred to as a vehicle arresting barrier (VAB) by the manufacturer, with the trademark name Dragnet®[22], is designed to prevent an errant vehicle from a penetrating work activity area and provide for a reasonably safe deceleration of the vehicle. The use of a VAB can reduce crash severity for motorized vehicle occupants in certain situations.



Figure 64. Portable vehicle arresting system.

Source: Cushion & Barrier, LLC

VAB devices are typically used when sections of a roadway are subject to frequent opening and closure over an extended work duration. The system is usually deployed by placing it across the entire mainline at the closure point, as well as at any downstream ramps or other potential entrance points. VAB devices are usually specified when they would be used on a regular basis, in lieu of stationing a law enforcement officer at the site. A secondary access point or bypass may be necessary to allow contractor vehicles to enter the work area. Consequently, to prevent unintentional intrusions, it is sometimes necessary to include contractual provisions requiring a human monitor, motion sensor warning system, or police officer at the bypass.

Situations that benefit from using VAB devices include:

- Areas where severe drop-offs are present, such as bridge-out situations.
- Sites where the consequences of an errant vehicle entering a section of closed roadway at high speed could be extremely severe (such as workers not expecting to encounter motorized traffic). This risk could be higher on nighttime projects.

Since these devices are designed to slow vehicles gradually for occupant safety, considerable deceleration distance is necessary behind the net (typically at least 120 feet for 60 mph roadways). At the time of publication of this document, the Dragnet® has successfully been crash tested to NCHRP Report 350 criteria. Section 2.1 of this document provides information about application of existing NCHRP Report 350 crash tested hardware.

## 6. Mandatory Use of Barrier in High-Hazard Situations

*By policy, some agencies have determined that the hazards associated with certain situations justify the use of temporary barriers with few or no exceptions. This optional section can be used to describe these situations and policies.*

*Establishing a policy mandating the use of barriers in selected situations can promote agency-wide consistency and could streamline the project development process by reducing the need for project-level engineering studies. Since these policies will typically focus on a few of the most hazardous situations, it is important to assure that designers understand that barriers are also considered for possible use in other situations based on site conditions.*

*The policies should be based on operational factors commonly observed within the jurisdiction. These policies may be developed using an agency's past engineering studies and experiences. In addition, useful guidance can be found in research reports such as:*

- *NCHRP Web-Only Document 105 (Final Report for NCHRP Report 581: Design of Construction Work Zones on High-Speed Highways).*
- *NCHRP 581 Design of Construction Work Zones on High-Speed Highways.*
- *Benefit/cost analysis studies, such as NCHRP 492 Roadside Safety Analysis Program (RSAP).*

*The resulting policies could be conveyed in the form of Standard Detail Drawings and/or in the form of a Policy Statement such as the example below.*

*Note: the items listed below are **only examples** of the type of criteria a State **may** decide to use for developing their own policies. Threshold values identified in purple in the example should be evaluated and revised by each State to fit their own past research, experience, engineering judgement, risk tolerance. The values provided below are not based on any field study or research conducted by the authors and only reflect the authors judgement to use as a starting point by States in developing their own policies.*

### **Sample Agency Policy**

*(Name of Agency)* has established an agency-wide policy requiring the use of positive protection when certain potentially hazardous conditions are anticipated. The use of an appropriate barrier system would be specified within the appropriate length-of-need when one or more of the following conditions exists:

- All bridges that remain open to traffic with permanent guardrails or parapets removed, regardless of traffic volume and expected work duration.
- All high-speed roadways with contraflow (opposite-side) operation, an expected work duration of *72 hours* or more, and a peak directional volume exceeding *1000* vehicles per hour per lane.
- All high-speed roadways with an expected duration of *one work shift* or longer where there is an abrupt edge drop between *3 and 12* inches in depth and the distance from the edge of the travelled way to the drop-off (measured in inches) *is less than 12 times* the

depth of the drop-off (for example a *three* inch drop *three* feet from the travelled way or a *12* inch drop less than *12* feet from the travelled way); or has a depth greater than *12* inches and the edge drop is less than *12* feet from the travelled way.

- All high-speed roadways where the clear distance to a hazardous fixed object is less than *50 percent* of the minimum value specified in *agency work zone clear zone design chart for conditions anticipated and the expected duration is 72 hours* or longer.
- Sites where scaffolding, cranes, bucket trucks, or similar lifting equipment will be immediately adjacent to the travelled way for a duration of *72 hours* or more.
- Sites where there is no path for workers to escape from motorized traffic (such as tunnels, bridges, etc.), when the duration of work is expected to be at least *two weeks*, and the limits of the work area remain substantially unchanged for that duration.

If a designer believes that the site conditions are unusual and the mandatory use of barriers should be waived, the appeal process discussed in Section 9 may be invoked. If the site meets the conditions for mandatory use of barriers but installing one is not feasible (e.g., due to insufficient space or inadequate anchoring structure), the designer would conduct an engineering study as discussed in Section 7.

The existence of a condition requiring the use of barriers within a portion of the project limits does not automatically mean positive protection is needed throughout the project, nor does it relieve the designer of the obligation to conduct an engineering study to evaluate the discretionary use of positive protection in the remaining areas of the project.

## 7. Positive Protection Decision Making Guidance

The positive protection decision-making processes involves a combination of objective analysis, design creativity, and engineering judgment. The goal is to select a solution that balances traffic and worker safety with cost and constructability considerations. Each major construction scenario (stage/phase) should be evaluated separately and all travel directions should be considered. Since positive protection devices are themselves physical obstacles, it is important to determine whether the need for a barrier system can be avoided by eliminating site hazards or reducing exposure risk.

Typically, the designer should determine and document the need for barriers by examining each of the following pathways:

- The site meets agency criteria for the mandatory use of barriers as described in Section 6.
- The site meets engineering criteria for the use of barriers as described in Steps 1-5 of Section 7.1.
- The use of barriers is justified based on engineering judgment as described in Step 6 of Section 7.1.

If the use of positive protection is not justified through any of these three pathways, or can be avoided through exposure control techniques, this finding should be documented in the project records.

### 7.1. Engineering Evaluation Process

This guide offers an example discretionary process for evaluating the need for positive protection. For simplicity, this process is described as a linear sequence of steps. In practice, the process is often iterative: decisions made in one-step could affect subsequent steps and other stages/phases of the project.

#### Step 1: Initial Work Zone Project Information Gathering

In this step, the designer gathers the information necessary to conduct an objective analysis. Much of this information should already be at hand for other aspects of work zone design and development of the Transportation Management Plan (TMP) *or Maintenance of Traffic (MOT) plan*. Data elements specifically needed for a positive protection evaluation include:

- Project location and type of work.
- Expected types of work operations.
- Expected duration of construction (or range of possible durations depending on traffic management options).
- Available space within the existing travelled way.
- Characteristics of the existing shoulders including width and drivability.
- Existing typical cross-sections and associated clear zone widths.
- Directional daily and hourly traffic volumes for the project area, including ramp and intersection volumes if available. If possible, also obtain information for any special or unusual traffic conditions such as holidays and special events that may fall within the construction timeframe.

- Characteristics of the existing traffic such as speeds, vehicle mix (heavy trucks versus cars), and predominant driver types (commuter, tourist/recreational, long-distance, etc.). Note that these characteristics may differ by time of day, day of week, etc.
- Feasible alternate routes and their attractiveness compared to the route where work will be taking place (this includes differences in travel time under non-construction conditions, and whether the alternate routes are able to accommodate heavy vehicles).

## **Step 2: Check Work Area Clear Zone Widths**

Using the clear zone distance criteria established by (*our agency*) as shown in *Table 4*, the designer should review the work area to identify locations where fixed objects, material stockpiles, and similar obstacles are likely to exist during construction.

*A highway agency guideline for clear zone distances in work zones should be developed for consistent application. Examples of minimum clear zone widths established by four State highway agencies are shown in Table 4. Three of the agencies set this distance using speed as the only factor, as suggested in Table 9-1 of the AASHTO Roadside Design Guide. A regression analysis of values used in Florida, Vermont, and Washington State indicates that the minimum clear zone width (measured in feet) is typically about 0.42 times the anticipated work zone running speed (in miles per hour). Some highway agencies (such as Illinois DOT) include additional criteria when setting work zone clear zone distances, such as traffic volumes, facility type, and roadside geometry.*

If this step results in a decision to use barriers throughout the entire project area, the designer may proceed to Step 6. Otherwise, continue to Step 3.

Table 4. Examples of highway agency Work Zone Guideline Clear Zone Distances [23]

<i>Florida DOT</i>		
<i>Work Zone Speed (mph)</i>	<i>Distance to Travel Lanes (ft)</i>	<i>Distance to Auxiliary Lanes (ft)</i>
<i>Curb &amp; Gutter Sections</i>	<i>4 ft beyond curb</i>	<i>4 ft beyond curb</i>
<i>30-40</i>	<i>14</i>	<i>10</i>
<i>45-50</i>	<i>18</i>	<i>10</i>
<i>55</i>	<i>24</i>	<i>15</i>
<i>60-70</i>	<i>30</i>	<i>18</i>

<i>Illinois DOT</i>			
<i>Work Zone Speed (mph)</i>	<i>Average Daily Traffic (ADT)</i>	<i>Front Slopes (ft)</i>	<i>Back Slopes (ft)</i>
<i>&lt;35</i>	<i>&lt;750</i>	<i>4 – 6</i>	<i>4 – 6</i>
	<i>750-1500</i>	<i>6 – 10</i>	<i>6 – 8</i>
	<i>1500-6000</i>	<i>6 – 10</i>	<i>8 – 10</i>
	<i>&gt;6000</i>	<i>10 – 12</i>	<i>10</i>
<i>35 – 50</i>	<i>&lt;750</i>	<i>6 – 10</i>	<i>4 – 8</i>
	<i>750-1500</i>	<i>10 – 14</i>	<i>8 – 10</i>
	<i>1500-6000</i>	<i>10 – 16</i>	<i>8 – 12</i>
	<i>&gt;6000</i>	<i>12 – 18</i>	<i>10 – 14</i>
<i>55</i>	<i>&lt;750</i>	<i>6 – 12</i>	<i>6 – 8</i>
	<i>750-1500</i>	<i>10 – 16</i>	<i>6 – 12</i>
	<i>1500-6000</i>	<i>12 – 18</i>	<i>10 – 14</i>
	<i>&gt;6000</i>	<i>14 – 20</i>	<i>10 – 16</i>
<i>60</i>	<i>&lt;750</i>	<i>10 – 16</i>	<i>6 – 10</i>
	<i>750-1500</i>	<i>12 – 20</i>	<i>8 – 14</i>
	<i>1500-6000</i>	<i>16 – 24</i>	<i>10 – 16</i>
	<i>&gt;6000</i>	<i>18 – 28</i>	<i>12 – 18</i>
<i>&lt;35</i>	<i>&lt;750</i>	<i>12 – 16</i>	<i>6 – 10</i>
	<i>750-1500</i>	<i>16 – 22</i>	<i>8 – 14</i>
	<i>1500-6000</i>	<i>18 – 26</i>	<i>10 – 18</i>
	<i>&gt;6000</i>	<i>18 – 28</i>	<i>14 – 18</i>

<i>Vermont DOT*</i>		
<i>Roadway Type</i>	<i>Work Zone Speed Limit (mph)</i>	<i>Distance from Travelled Way (ft)</i>
<i>State/US Routes</i>	<i>All</i>	<i>10</i>
<i>Interstates</i>	<i>30-40</i>	<i>13</i>
	<i>45-50</i>	<i>16</i>
	<i>55</i>	<i>23</i>
	<i>60-70</i>	<i>30</i>

\* Vermont follows the criteria in Table 9-1 of the AASHTO Roadside Design Guide.

<i>Washington State DOT</i>	
<i>Work Zone Speed (mph)</i>	<i>Distance to Travel Lanes (ft)</i>
<i>≤35</i>	<i>10</i>
<i>40</i>	<i>15</i>
<i>45-50</i>	<i>20</i>
<i>≥ 60</i>	<i>30</i>

### Step 3: Check Distance to Drop-Offs

Steep slopes and abrupt drop-offs, shown in Figure 65, occur in many work zones, especially when pavements or structures are being replaced or there is a major change in the finished elevation of the roadway. Using the drop-off distance criteria established by *(our agency)* as shown in *Table 5*, the designer should review the work area to identify locations where these hazards are likely to exist during construction.



Figure 65. Abrupt pavement edge drops creates the potential for serious crashes.

Source: Wisconsin DOT

*As a category separate from clear zones, many agencies have developed guidelines for justifying positive protection for drop-off conditions based on variables such as distance from traveled way, drop-off depth, traffic volume, and work duration. Each agency should develop its own drop off conditions where positive protection is justified. Brief summaries of the criteria used by 12 State DOTs are shown in Table 5.*

Table 5. *Examples of highway agency drop-off values for consideration of positive protection.*

<i>Agency</i>	<i>Criteria</i>
<i>California DOT</i>	<i>Drop-off depth &gt; 6 inches, located within 8 feet of travel way; special engineering consideration for all drop-offs &gt; 2.5 feet.</i>
<i>Florida DOT</i>	<i>Drop-off depth &gt; 3 inches, located within 12 feet, project duration &gt; 1 day</i>
<i>Iowa DOT</i>	<i>Drop-off depth &gt; 10 inches, located with 10 feet of travel way.</i>
<i>Maryland DOT</i>	<i>Drop-off depth &gt; 2.5 inches, located adjacent to travel way</i>
<i>Minnesota DOT</i>	<i>Optional for drop-off depth &gt; 4 inches, if no wedge, located adjacent to travel way, speed &gt; 30 mph, project duration &gt; 3 days, length &lt; 50 feet; if 12 inches, recommended.</i>
<i>Montana DOT</i>	<i>Drop-off located with 30 feet of traveled way, if no wedge provided, exposures exceeding 48 hours, spacing factor &lt; 20 feet by formula</i>
<i>New Hampshire DOT</i>	<i>Drop-off depth &gt; 3 inches to &lt; 5 feet located adjacent to travel way, and edge treatments are not possible or if length of exposure needs added protection for workers and/or traveling public, on any highway, speed limit &lt; or = 45 mph</i>

North Dakota DOT	Drop-off depth > 5 inches located between travel lanes, drop-off depth > 12 inches, located adjacent to travel way speed; when speed limit > 30 mph, project duration > 7 days, work area length > 50 feet
Ohio DOT	Drop-off depth > 5 inches located between travel lanes, drop-off depth > 2 feet located within 30 feet of travel way, overnight exposure
West Virginia DOT	Drop-off depth > 3 inches, project duration > 48 hours, speed limit > 45 mph, located with 30 feet of travel way on multilane highways, located within 20 feet of travel way on undivided highways.
Virginia DOT	Drop-off depth > 12 inches located 4 to 5 feet from travel way
Wisconsin DOT	On freeways/expressways when drop-off expected > 3 days and length > 100 feet drop-off > 6 inches located 2 feet or less from travel way; drop-off > 12 inches located < 4 feet or less from travel way; drop-off > 24 inches located < 12 feet or less from travel way; or drop-off > 37 inches located < 20 feet or less from travel way.
<p><i>Note: The criteria shown for each highway agency are only general values for a limited number of conditions. Most highway agencies have a much longer discussion on different criteria and caveats, or use tables for different data factors.</i></p> <p><i>Source: TOPS Lab review of individual state design manuals in 2014.</i></p>	

For asphalt paving, a simple and cost-effective way to promote pavement edge safety is to use the Safety Edge<sup>SM</sup> treatment developed on behalf of FHWA[24]. The Safety Edge<sup>SM</sup> is created by using a shaping device that can be attached to asphalt paving machines to create a 30 degree sloped edge. Normal paving operations without the shaping device leave a near vertical edge. If graded shoulder material erodes away over time from the vertical edge, a drop-off situation occurs which can cause difficulty for drivers to return safely to the roadway if they leave the paved surface at high speeds. The sloped edge can reduce the risks to drivers during the correction maneuver.

*If this step results in a decision to use barriers throughout the entire project area, the designer may proceed to Step 6. Otherwise, continue to Step 4.*

#### **Step 4: Evaluate the Need for Positive Protection for Worker Protection**

Several factors affect the probability of a worker being struck by an errant vehicle. These include:

- **Project Duration.** All other things being equal, the risk of a worker being struck by an errant vehicle is roughly proportional to the amount of time unprotected workers are present at the site.
- **Distance from the Traveled Way to the Workforce.** As the lateral buffer space between live traffic and the workforce increases, the probability of an errant vehicle intrusion into the work area declines. All other things being equal, a wide lateral buffer is safer for the workforce than a narrow one.

- **Traffic volume and traffic speed.** Speed, volume, and worker risk relationships are complicated. On a lightly traveled roadway, the risk of an errant vehicle striking a worker can be expected to rise roughly in proportion to the traffic volume. In moderately heavy traffic on roadway with two or more lanes, vehicle-to-vehicle interactions begin to occur: a worker might be at least partially shielded from an errant vehicle by another vehicle in an adjacent lane (possibly resulting in a vehicle-vehicle crash instead of a vehicle-worker crash). At very high traffic volumes (close to the capacity of the roadway) speeds tend to go down, which potentially gives some drivers a few extra seconds to recover from an errant maneuver.

A study prepared by Texas A&M Transportation Institute (TTI) on behalf of Idaho DOT used Roadside Safety Analysis Program (RSAP-3) safety analysis software to estimate the benefits of barrier for worker protection [25]. This is essentially a benefit/cost analysis method: the “cost” is the transportation agency’s cost to deploy the barrier and the “benefit” is the statistical reduction in the probability of a worker injury or fatality. The analysis can be broken down into the following steps:

#### A. Compute Analysis Parameters.

**C = Barrier Cost (dollars).** In many cases, this computation will be straightforward: simply multiply the anticipated unit cost for the barrier by the length of need. For example, if the length of the required barrier is 0.5 miles and the estimated cost for the duration of the project is \$60 per lineal foot, the cost would be:

$$C = \$60/\text{feet} \times 2640 \text{ feet} = \$158,400$$

In some cases, the cost computation will be more complicated:

- Multiple barrier runs might be required, e.g., one on each side of the traveled way.
- There could be multiple bid items that need to be combined or weighted (for example, an initial cost to deploy the barrier, and a separate charge for relocating the barrier as work progresses).
- Crashworthy end treatments are sometimes a separate bid item that needs to be included when computing the overall cost of the barrier system.
- There could be one-time costs to prepare the roadway for the barrier system, such as earthwork or temporary paving necessary to provide firm surfaces under the barrier, or to remove existing obstacles from the deflection space.

**D = Project Duration (years).** Most contracts have a fixed completion schedule such as 120 days from the date the contract is awarded. Typically, on-road work will only occur for a portion of that time (for example, workers might not be present on the roadway during the mobilization and landscaping phases). In addition, not all projects work 24 hours a day or 7 days a week. The worker exposure duration can be computed as follows:

$$D = \text{Actual working days} \times \text{Hours Worked per Day} \div 8766 \text{ hours/year}$$

When estimating the actual working days, remember to exclude weekends and holidays unless it is expected that work will be done at those times. Note that this calculation is independent of the number of workers on site. (On average, there are  $24 \times 365.25 = 8766$  hours in a year).

**F = Value of a Statistical Life (dollars).** Performing benefit/cost analysis for safety projects requires establishing a monetary value that captures how much can reasonably be spent to prevent a fatal collision. Non-fatal worker casualties are also considered in the worker protection benefit calculations: they are embedded in the formulas as fractions of the value of a statistical life.

*In the absence of state-specific guidance, the following national values may be used for the value of a statistical life:*

- *FHWA: \$9,200,000 (2014)*
- *National Safety Council: \$9,887,000 (2014)*

**LA = Active Work Area Length (miles).** In most cases, workers are present in only a portion of the total length of the work zone. For example, the total length of the work zone might be 1 mile (5280 feet), but at any given time the workforce might be concentrated in an area about 1/8 mile (660 feet) long.

**TD = Directional Daily Traffic Volume (vehicles/day).** The directional volume is used for freeway analysis. It is the estimated average total number of vehicles per day passing through the work zone in the direction where the barrier is being considered for use. In most cases this is simply half of the total bi-directional traffic volume, but adjustments might need to be made for site-specific directional flow patterns, including any increases or decreases in traffic volume resulting from the construction itself (for example, volume could be reduced because of upstream ramp closures). If Annual Average Daily Traffic Volume (AADT) is used as the starting point for this calculation, adjustments should be made to account for the month(s) of the year when the work will take place (in many parts of the United States, summer traffic volumes are higher than winter volumes).

**TR = Roadway Daily Traffic Volume (vehicles/day).** The total volume for both directions combined is used for analysis of two-lane highways. If Annual Average Daily Traffic Volume (AADT) is used as the starting point for this calculation, adjustments should be made to account for the month(s) of the year when the work will take place (in many parts of the United States, summer traffic volumes are higher than winter volumes) and for any changes in volume resulting from the construction itself.

**n = Lateral Buffer Space (feet).** This is the anticipated distance between live traffic and the workforce, if no barrier system is used, and will typically range from zero to 24 feet. (Caution: This calculation could produce inaccurate results for buffer widths significantly more than 24 feet).

**s = Work Zone Traffic Speed (mph).** This is the anticipated *actual running speed* in the work zone, typically in the range of 50 to 70 mph for freeways and 45 to 55 mph for two-

lane rural highways. (Caution: This calculation could produce inaccurate results for speeds significantly below 45 mph or above 70 mph).

## B. Compute Crash Reduction Benefits

**Freeways:** The crash reduction benefits B (in dollars) for a freeway can be computed from the following formula:

$$B = \frac{D \times F \times L_A \times 0.005 T_D^{0.344} \times (-0.000516n^2 - 0.00713n + 1)}{(0.0000859s^2 + 0.00827s)}$$

[Eq. 1]

Figure 66. Equation for Crash Reduction Benefits on Freeways

**Two-Lane Rural Highways:** The crash reduction benefits B (in dollars) for a two-lane rural highway can be computed from the following formula:

$$B = D \times F \times L_A \times 0.00831 T_R^{0.225} \times (-0.000516n^2 - 0.00713n + 1) \times 0.0146s$$

[Eq. 2]

Figure 67. Equation for Crash Reduction Benefits on Two-Lane Rural Highways

## C. Compute Benefit/Cost Ratio

$$\text{Benefit/Cost Ratio} = B \div C$$

[Eq. 3]

Figure 68. Equation for Benefit/Cost Ratio

Interpretation: If the Benefit/Cost ratio is greater than 1.0, the use of barriers for worker protection can be considered cost-effective. If the ratio is slightly less than 1.0, the use of barriers should be considered on a discretionary basis considering other site conditions. If the ratio is significantly less than 1.0, barriers are probably not cost-effective for worker-protection purposes.

*If this computation resulted in a decision to use barriers throughout the entire project area, or if the site has no edge drops, the designer may proceed to Step 6. Otherwise, continue to Step 5.*

## Worked Example 1

### Situation:

Workers will be present on a freeway five days a week, Monday through Friday, from 6:00 AM to 4:00 PM for 24 weeks (5½ months). The barrier would be 2 miles long and the active portion of the workspace (where workers are present) is expected to be ¼ mile at a time. If the project is left unprotected, the workers will typically be 8 feet from the edge of the travelled way. The total traffic volume in both directions is 60,000 vehicles per day, of which 55% is traveling in the direction that would be protected if barriers were used. Although freeway normally has a 70 mph speed limit, the typical speed through the work zone is expected to be 65 mph. The anticipated bid price for the barrier is \$50 per linear foot. The agency's policy is to use the Federal value of a statistical life (\$9.2 million as of 2014). Is the use of barriers for worker protection cost-effective?

### Solution:

The Benefit/Cost Ratio can be calculated using Equations 1 and 3:

$$C = \$50/\text{foot} \times 2 \text{ miles} \times 5280 \text{ feet/mile} = \$528,000$$

$$B = D \times F \times L_A \times 0.005T_D^{0.344} \times (-0.000516n^2 - 0.00713n + 1) \times (0.0000859s^2 + 0.00827s)$$

$$D = 5 \text{ days/week} \times 24 \text{ weeks} \times 10 \text{ working hours/day} \div 8766 \text{ hours/year} = 0.137 \text{ exposure years}$$

$$F = \$9,200,000$$

$$L_A = 0.25 \text{ miles}$$

$$T_D = 55\% \times 60,000 \text{ vehicle/day} = 33,000$$

$$n = 8 \text{ feet}$$

$$s = 65 \text{ mile per hour}$$

$$\begin{aligned} B &= 0.137 \times \$9,200,000 \times 0.25 \times 0.005(33,000^{0.344}) \times (-0.000516 \times 8^2 - 0.00713 \times 8 + 1) \times (0.0000859 \times 65^2 + 0.00827 \times 65) \\ &= \$46,200 \end{aligned}$$

$$B/C = \$46,200 \div \$528,000 = 0.09$$

*Conclusion: Since  $0.09 < 1$ , the use of barriers for worker protection alone is not cost-effective in this case.*

## Worked Example 2

### Situation:

Workers will be present on a freeway, Monday through Saturday, from 6:00 AM to 10:00 PM for 36 weeks (8½ months). The barrier would be 1 mile long and the active portion of the workspace (where workers are present) is expected to be ¼ mile at a time. If the project is left unprotected, the workers will typically be 3 feet from the edge of the travelled way. The total traffic volume in both directions is 120,000 vehicles per day of which 55% is traveling in the direction that would be protected if barriers were used. Although freeway normally has a 70 mph speed limit, the typical speed through the work zone is expected to be 65 mph. The anticipated bid price for the barrier is \$50 per linear foot. The agency's policy is to use the Federal value of a statistical life (\$9.2 million as of 2014). Is the use of barriers for worker protection cost-effective?

### Solution:

The Benefit/Cost Ratio can be calculated using Equations 1 and 3:

$$C = \$50/\text{foot} \times 1 \text{ mile} \times 5280 \text{ feet/mile} = \$264,000$$

$$B = D \times F \times L_A \times 0.005T_D^{0.344} \times (-0.000516n^2 - 0.00713n + 1) \times (0.0000859s^2 + 0.00827s)$$

$$D = 6 \text{ days/week} \times 36 \text{ weeks} \times 16 \text{ working hours/day} \div 8766 \text{ hours/year} = 0.394 \text{ exposure years}$$

$$F = \$9,200,000$$

$$L_A = 0.25 \text{ miles}$$

$$T_D = 55\% \times 120,000 \text{ vehicle/day} = 66,000$$

$$n = 3 \text{ feet}$$

$$s = 65 \text{ mile per hour}$$

$$B = 0.394 \times \$9,200,000 \times 0.25 \times 0.005(66,000^{0.344}) \times [-0.000516(3^2) - 0.00713(3) + 1] \times [0.0000859(65)^2 + 0.00827(65)] \\ = \$181,000$$

$$B/C = \$181,000 \div \$264,000 = 0.69$$

*Conclusion: Since  $0.69 < 1.00$ , the use of barriers for worker protection alone is not cost-effective in this case, but if this result is found in combination with other site conditions that marginally justify the use of barriers, their use might be considered based on engineering judgment.*

## Step 5: Evaluate the Need for Positive Protection for Worker Protection Combined with Edge Drops

If a site has both unprotected workers and edge drops, the combination of hazards potentially justifies the use of barriers even though neither hazard is sufficient by itself. The computation is derived from the same RSAP-3 based study described in Step 4 and the procedure is very similar (the equations have different coefficients). For simplicity, the study assumed that the drop-off hazard is located 3 feet from the travelled way and has a depth of 6 inches or more, resulting in a high probability of vehicle rollover.

**A. Compute analysis parameters.** The computation of C, D, F, L<sub>A</sub>, T<sub>D</sub>, T<sub>R</sub>, n and s is identical to Step 4.

### B. Compute Crash Reduction Benefits

**Freeways:** The crash reduction benefits B (in dollars) for a freeway can be computed from the following formula:

$$B = D \times F \times L_A \times 0.00554T_D^{0.368} \times (-0.000516n^2 - 0.00713n + 1) \times (0.0000455s^2 + 0.0111s) \quad [Eq. 4]$$

**Two-Lane Rural Highways:** The crash reduction benefits B (in dollars) for a freeway can be computed from the following formula:

$$B = D \times F \times L_A \times 0.0112T_T^{0.225} \times (-0.000516n^2 - 0.00713n + 1) \times 0.0144s \quad [Eq. 5]$$

### C. Compute Benefit/Cost Ratio

$$\text{Benefit/Cost Ratio} = B \div C \quad [Eq. 6]$$

The interpretation of the B/C ratio is the same as in Step 4C.

*If this computation resulted in a decision to use barrier throughout the entire project area, the designer may proceed to Step 7. Otherwise, continue to Step 6.*

### Worked Example 3

#### Situation:

Workers will be present on a freeway, Monday through Saturday, from 6:00 AM to 10:00 PM for 39 weeks (9 months). The barrier would be 1 mile long and the active portion of the workspace (where workers are present) is expected to be ¼ mile at a time. If the project is left unprotected, the workers will typically be 3 feet from the edge of the travelled way where an edge drop is also present. The total traffic volume in both directions is 120,000 vehicles per day of which 55% is traveling in the direction that would be protected if barriers were used. Although freeway normally has a 70 mph speed limit, the typical speed through the work zone is expected to be 65 mph. The anticipated bid price for the barrier is \$50 per linear foot. The agency's policy is to use the Federal value of a statistical life (\$9.2 million as of 2014). Is the use of barrier for the combination of worker and edge-drop protection cost-effective?

#### Solution:

The Benefit/Cost Ratio can be calculated using Equations 4 and 6:

$$C = \$50/\text{foot} \times 1 \text{ miles} \times 5280 \text{ feet/mi} = \$264,000$$

$$B = D \times F \times L_A \times 0.00554T_D^{0.368} \times (-0.000516n^2 - 0.00713n + 1) \times (0.0000455s^2 + 0.00111s)$$

$$D = 6 \text{ days/week} \times 39 \text{ weeks} \times 16 \text{ working hours/day} \div 8766 \text{ hours/year} = 0.427 \text{ exposure years}$$

$$F = \$9,200,000$$

$$L_A = 0.25 \text{ miles}$$

$$T_D = 55\% \times 120,000 \text{ vehicle/day} = 66,000$$

$$n = 3 \text{ feet}$$

$$s = 65 \text{ mph}$$

$$B = 0.427 \times 9,200,000 \times 0.25 \times 0.00554 \times 66,000^{0.368} \times (-0.000516 \times 3^2 - 0.00713 \times 3 + 1) \times (0.0000455 \times 65^2 + 0.00111 \times 65) \\ = \$286,000$$

$$B/C = \$286,000 \div \$264,000 = 1.08$$

*Conclusion: Since  $1.08 > 1$ , the use of barriers for combined worker and edge-drop protection is cost-effective in this case.*

## **Step 6: Identify Situations Justifying the Use of Barrier Based on Engineering Judgment**

It is possible that a site could include a situation (or combination of situations) that do not meet the criteria for positive protection described in the previous steps, but where positive protection is nevertheless justified based on good engineering judgment. The designer should review the project area to determine whether traffic conditions with elevated risk of a fatality or serious injury are likely to exist if barriers were not used. Although it is not possible to create a comprehensive list of all higher-risk situations, some examples include:

- Locations with serious or severe non-conformance with geometric standards near the work activity area, such as sharp curves, narrow lanes, or limited sight distance.
- Locations where workers have no way to escape the path of an errant driver. This situation potentially exists when working at tunnels, major bridges, or canyon-like roadway segments with narrow shoulders. It might also exist if work operations will be conducted in the center lanes of a multi-lane highway (with live traffic on both sides).
- Locations where there is a likelihood of significant speed differentials between lanes. For example, it could be necessary to use barriers to prevent freeway mainline drivers from encroaching into acceleration/deceleration space at ramps or to prevent unwanted access to HOV or special use lanes.
- Locations where ramps or lane closure merges could de-stabilize traffic flow and there is not adequate buffer space to allow motorist recovery.
- High-speed roadways with exceptionally high truck volumes (for example, access roads serving seaports or intermodal rail terminals).
- Locations with speed limits beyond the range of previous research (i.e., 80 mph or greater).
- Research indicates that running two-way traffic on one side of a divided highway substantially increases the likelihood and severity of truck related crashes compared to normal two-way divided operation [26]. Therefore, the use of barriers should be considered when two-way operation on one side of an ordinarily divided highway is proposed. At a minimum, the traffic volume, speed, lane width, shoulder width, and crossover geometry should be considered when making this judgment.
- Placing bicyclists or pedestrians in the proximity to heavy or fast-moving traffic could increase crash risk or severity compared to the non-construction condition.

Because of the wide range of work zone layouts, it is not possible to create a comprehensive list of all higher-risk situations. Designers should use engineering judgment to evaluate each layout and determine whether it would pose a significant risk of a fatality or serious injury if barriers were not used. The severity and duration of the risk should be taken into consideration. Table 6 provides additional information about factors which potentially justify the use (or non-use) of barrier based on engineering judgment.

Table 6. Examples of Factors to Consider in Positive Protection Decisions

<p><b>Roadway Classification.</b> Although positive protection is used on many types of roadways, it is often particularly valuable on freeways and other high-speed access controlled highways. For example, when it is necessary to put two-way traffic on one side of what is ordinarily a divided highway, temporary barriers can help separate the opposing traffic flows to prevent head-on collisions in crossovers and the two-way section.</p> <p><b>Project Scope and Duration.</b> Barrier delivery and installation accounts for most of the cost of deploying a positive protection system. As a result, barriers and other positive protection devices become increasingly cost-effective as the project duration increases.</p> <p><b>Traffic Volume.</b> Although the risk of a crash generally increases with traffic volume, crash severity sometimes decreases under very high volume conditions because of reduced speeds during times of congestion. Traffic that fluctuates between free-flow and stop-and-go conditions is perhaps the most-risky situation. As the volume of commercial trucks increases, so does the risk of heavy vehicle intrusion into the workspace. Urban freeways are often viable candidates for positive protection because of high traffic volumes and a greater likelihood of unstable (stop-and-go) traffic.</p> <p>Most sites have predictable traffic volume patterns that vary by time-of-day, day-of-week, and month-of-year. Nighttime or off-peak construction often reduces exposure compared to day work. Nevertheless, the benefits of reduced traffic exposure are sometimes offset by reduced visibility, higher speeds (due to free-flowing traffic), and an increased proportion of drowsy or impaired drivers.</p> <p><b>Anticipated Work Zone Speeds.</b> Road user and worker injury severity increases with speed. When evaluating a proposed barrier system, both the posted speed limit and the anticipated 85<sup>th</sup> percentile speed should be considered.</p> <p><b>Roadway and Roadside Geometry.</b> The geometric characteristics of the roadside and the work area are an important consideration in decisions about whether to use positive protection. For example, severe curvature, narrow lanes, restricted sight distance, or narrow shoulders could place workers and motorists at increased risk, possibly justifying the use of positive protection. Roadside geometry such as the distance to fixed objects and the depth and slope of drop-offs and embankments should also be considered.</p>	<p><b>Work Area Access.</b> Many projects require work vehicles, material delivery trucks, and contractor personnel to enter and exit the workspace frequently. As a result, the decision to use barrier is often intertwined with work zone access and egress design. The use of barrier gates and emergency-vehicle-only access points can help address these issues to some degree. If barrier is used, it is important to avoid blunt ends at work vehicle access points.</p> <p><b>Worker Location and Risk Exposure.</b> As discussed in Step 5 of Section 7.1, work operations that place workers close to live high-speed traffic lanes for extended periods are candidates for positive protection. As the <i>lateral</i> buffer space between drivers and workers decreases, the justification for using positive protection becomes stronger. This is especially true if little or no <i>longitudinal</i> buffer is available to give drivers space for evasive maneuvers as they approach the workforce.</p> <p>Conversely, work activities that are only present at a specific location for a relatively short time (such as joint repair, pavement resurfacing, or traffic control installation/removal) are less likely to justify the use of positive protection, particularly if exposure control measures are feasible. If mobile barriers are available, their use should be considered.</p> <p>Positive protection should be considered at sites where workers cannot easily escape the path of errant drivers. This situation can occur in tunnel and bridge projects and canyon-like freeway cuts, especially if the shoulders are narrow. It can also occur when work is planned to be done in a center lane with traffic passing on both sides.</p> <p><b>Risks During Installation, Use, and Removal.</b> Striking a temporary barrier can potentially result in serious injuries to vehicle occupants. Therefore, a general rule of thumb is that the system should protect against the risk of striking something that would result in more serious injury than that caused by striking the positive protection device itself. Consideration should also be given to the risk exposure created by placement and removal of the positive protection equipment.</p> <p><b>Exposure Control.</b> Methods to minimize or eliminate exposure for workers and motorists should be considered early in the planning stages of a project. As discussed in more detail in Step 7 of Section 7.1, typical methods include traffic diversion, full roadway closures, and working during off-peak periods such as nights and weekends.</p>
---	---

## Step 7: Identify Potential Exposure Control Measures (ECMs)

In some cases, alternative design measures can reduce or eliminate the need for positive protection. In this step, the designer evaluates alternative work zone design treatments to mitigate hazards and reduce risks to workers and road users.

As noted in Section 1.2, it is useful to distinguish “hazards” (sources of potential damage, harm, or adverse health effects) from “risk” (the probability of harm resulting from a hazard). Some Exposure Control Measures (ECMs) reduce or eliminate hazards (for example by re-routing traffic onto a safer facility), while others reduce risk (for example by limiting the amount of time that the hazardous condition exists, or by dropping speeds to a level that is unlikely to result in serious injury in case of a driver or worker error).

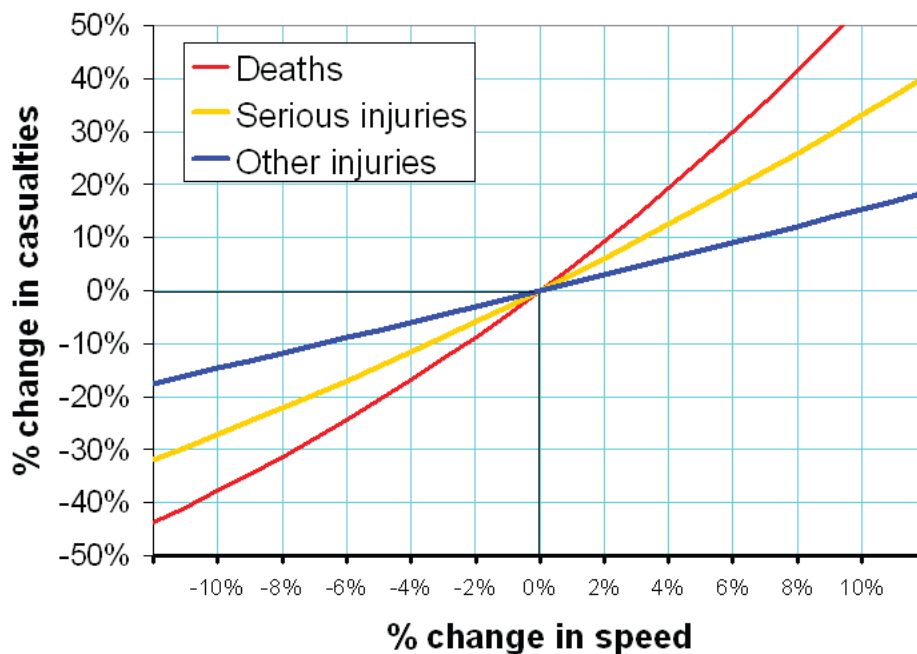

Figure 69. Relationships between speed reduction and casualty reduction (Nilsson 1981).

Source: NZTA

There are several broad categories of ECMs. They are listed here in roughly *decreasing* order of effectiveness:

- **Full closure** of the roadway where work will be taking place.
- **Reducing speed.** Speed strongly affects both the chance that a crash will occur and its severity. Finch et al. (1994) found that for every 1 mph reduction in speed, the overall number of injury crashes decreases by 5 percent. As illustrated in Figure 69, Nilsson (1981) found that the relationship between crash severity and speed is non-linear: even somewhat small reductions in speed greatly reduce the likelihood of death or serious injury. The relationship between speed and stopping distance is also non-linear; for example, a 40% increase in speed (from 50 to 70 mph) increases the stopping distance by

about 80%. Therefore, reducing speeds (or improving speed limit compliance) can be a valuable ECM.

- **Increasing lateral buffer space.** In general, the greater the lateral distance between the travelled way and the hazard, the less likely it is to be hit. A wider buffer also increases the probability that an out-of-lane driver can recover to a safe position before striking the hazard.
- **Reducing hazard severity.** In some cases, it may be possible to mitigate the hazard by modifying the work zone design. Examples include reducing drop-offs, making side slopes more gradual, treating loose gravel running surfaces or shoulders with a thin overlay or sealcoat to reduce the risk of losing traction, or providing longitudinal rumble strips to warn drivers that they are out-of-lane.
- **Reducing traffic volume.** All other things being equal, it is reasonable to expect that the likelihood of a crash is proportional to the total number of drivers passing through the hazardous area.
- **Reducing hazard length or duration.** The likelihood of a crash can be mitigated by changing the work zone design to reduce the length of the hazardous area, for example by immediately backfilling a trench that parallels the roadway. Another potential intervention is to reduce the number of hours or days when the hazardous condition exists, for example by using prefabricated components instead of building them on-site. All other things being equal, it is reasonable to expect that risk is roughly proportional to the length of the hazardous area and the duration of the hazardous condition.
- **Reducing the number of workers in the hazardous area.** The likelihood of a crash that involves a worker can reasonably be assumed proportional to the number of workers who are exposed to the hazard.

It is important to note that some ECMs potentially conflict with one another. For example, increasing the size of the workforce could reduce driver exposure to the hazard by getting the job done faster, but would increase the number of workers exposed. Similarly, using prefabricated components could reduce worker and driver exposure duration, but installation might need larger equipment that extends further into the lateral buffer space. For making these decisions in comparing ECMs, designers and agencies usually rely on engineering judgement.

Some questions for the designer to consider include the following:

- Can the work area be closed to all traffic, for example using a full detour?
- Is a limited-duration full closure feasible, for example a full closure over a weekend?
- Can the traffic volume be substantially reduced by detouring part of the traffic, closing ramps, or shifting most road users to another travel mode?
- Can the hours of work be adjusted to times when traffic volumes are low (for example, less than 200 vehicles per hour per open lane)?
- Can speeds through the hazardous area be significantly reduced through the use of pace vehicles, heavy enforcement, or automated enforcement?
- Can portions of the work be prefabricated off site to reduce the number of hours when the travelling public is exposed to the hazardous condition?
- Can the physical layout of the work zone be changed to reduce drop-offs, flatten side slopes, or increase clear zones?

The designer should develop a preliminary cost estimate for each exposure control measure that appears feasible. The estimate should include both the direct costs to the project and increases in road user costs such as increased travel time and additional fuel consumption associated with detours. These costs can then be compared to the cost of providing positive protection.

### **Step 8: Re-Evaluate Hazards for Each Potential Exposure Control Measure**

In this step, the hazards evaluated in Steps 2-6 are re-evaluated to determine whether the proposed ECMs are effective enough to reduce or eliminate the need for barrier. This includes checking the clear zones, traffic factors, and worker exposure for each reasonable combination of ECMs.

The strategy that is most responsive to the evaluation factors on an overall basis should be selected. A decision can then be made as to the use of positive protection based on the anticipated risks to workers and road users.

### **Step 9: Document Decisions**

The outcome of Steps 2-8 should be documented in the project records to indicate the rationale for the use (or non-use) of barriers in each major roadway segment, direction, and project stage/phase. Documentation should include the input data and assumptions, computations, and the designer's findings or recommendations. Decisions made based on engineering judgment should be described in reasonable detail.

*Insert any agency-specific documentation instructions here (also see Section 9).*

### **Step 10: Enhance Overall Project Safety**

Supplemental safety and exposure mitigation measures should be considered as part of the overall Transportation Management Plan (TMP) development process. Examples include work zone speed management measures (such as increased traffic enforcement or the use of pilot/pace vehicles), closer spacing of barricades and other warning devices, more conspicuous pavement markings, temporary traffic signals, and the judicious use of devices such as portable changeable message signs.

## **7.2. Other Positive Protection Decision Making Guidance Processes**

*There are numerous examples of research studies and agency processes that have been developed and/or proposed for use in positive protection decision-making guidance. At one end of the spectrum are more subjective guidance procedures requiring only minimal input data and rely more on designer engineering judgement, to the other end that are more analytical and require large amounts of information about the project. The process formats may be presented as flow charts, decision trees, numbered step processes, charts, or as narrative statements. The references are shown in alphabetical order below. This guide makes no recommendations on the strengths or weaknesses of the listed documents; they are simply provided for agencies to review when establishing or updating their own design guidance. The list is not all-inclusive and represents only a range of examples.*

- *Alabama – Guideline for Operations – “Temporary Traffic Control Devices, Section I. Positive Protection Devices”*
- *American Traffic Safety Services Association - “Guidelines on the Use of Positive Protection in Temporary Traffic Control Zones”*
- *Colorado – Guidelines for the Use of Positive Protection in Work Zones”*
- *Kansas – research report numbered K-TRAN:KU-10-3, entitled “Proposed Positive Protection Guidance for Kansas: Synthesis of Work Zone Positive Protection Devices and State of Practice, Appendix B Proposed Positive Protection Guidance for Kansas” published December 2012*
- *New Hampshire – “Positive Protection Guidance in Work Zones”*
- *Texas – research report numbered FHWA/TX-11/0-6163-1, entitled “Work Zone Positive Protection Guidelines”, published May 2011*
- *Virginia – Work Area Protection Manual, Appendix A Guidelines for the Use of Barrier/Channelizing Devices in Work Zones*

## 8. Selecting Barrier Types

After identifying sites within the project area where barriers are necessary, the designer should determine which types of barrier system or systems will be specified (or allowed). Table 7 provides an overview of the characteristics of some of the work zone positive protection systems described in this Guide. In some cases, different systems will be appropriate for individual areas within the project limits. For example, a major freeway construction project may also require modifying local street access. In this case, concrete or steel barrier might be necessary for the freeway mainline, but it might be advantageous to allow the contractor to use water-filled plastic barrier on the lower-speed local street portions of the project.

Many highway agencies have established barrier specifications and developed standard detail drawings based on their specifications. This is often advantageous, but the designer should remain alert for situations where an option that provides equal performance at lower cost is available, or where the use of a system that exceeds the agency's ordinary specifications is appropriate. For example, if the agency-approved barrier has been certified to Test Level 3 and the site has an unusually high volume of heavy trucks, the use of a Test Level 4 system might be justified. Similarly, the deflection of the agency-standard barrier could exceed the available space, necessitating a switch to a more rigid system. In addition, broadening the range of alternative systems that can be proposed by contractors could result in cost savings and/or more robust competition among potential bidders. For example, at remote sites the use of steel barriers might reduce overall cost due to lower trucking/delivery expense.

Table 7. Overview of Some Positive Protection Systems [25].

Positive Protection Device	Most Appropriate Projects and Locations For Use	Relative Costs and Benefits	Other Considerations
<b>Portable Concrete Barriers</b>	Longer duration stationary projects; areas with limited room for barrier deflection such as bridges and tunnels; drop-off conditions; worker exposure concerns	Substantial installation and removal costs; provide greater benefit on stationary activities compared with those that move such as pavement resurfacing	Require space for placement equipment; contractor access to work area; protection for exposed barrier ends
<b>Ballast Filled Barriers</b>	Low-speed urban projects; projects with limited space for concrete barrier placement equipment; areas with room for larger deflection, if needed (some water filled barriers are designed to minimize deflection)	Potentially lower installation and removal costs as they can be placed and removed by hand when unfilled	May be filled with water or sand; consider ballast material transport options, handling, and disposal, along with potential temperature issues (mitigated with environmentally sensitive anti-freeze)
<b>Steel Barriers</b>	Short-duration projects such as pavement rehabilitation and maintenance; areas with room for larger deflection (if anchored, deflection can be minimized). May also be used on long-term projects	Lower transport costs due to their lightweight, stackable design, quick installation	Lateral displacement is generally 6 to 8 feet (depending on impacting vehicle); may be anchored to minimize deflection
<b>Moveable Concrete Barriers</b>	Longer duration projects; projects where the traffic control configuration is changed frequently (where lanes are opened and/or closed on a daily or nightly basis)	Substantial cost and effort to install; provide benefit on projects where lane configuration changes often	Reconfiguration of the barrier can be accomplished quickly and safely; may be used to optimize directional capacity
<b>Shadow Vehicles with TMAs</b>	Mobile, short-duration, and short-term stationary projects such as striping, signal maintenance, vegetation control, pavement patching and repairs, and joint and crack sealing; locations where other barriers may be impractical due to the mobility of the operation	Costs include those for truck, attenuator, and driver – undamaged attenuator may be reused on other projects to spread costs	Adequate roll ahead distance is required to protect workers; consider the potential for motorists to access area between shadow vehicles and workers
<b>Vehicle Arresting Systems</b>	Longer term projects where the installation is used over an extended period, such as nightly closure of a roadway over an extended period; used to close an entire area and stop errant vehicles from intruding	Fixed end anchors require substantial effort to install; temporary anchors provide a lower cost solution for short-term applications	Requires adequate buffer space to allow vehicle to slow to a stop; consider work vehicle access to the closed area

Source: Guidelines on the Use of Positive Protection in Temporary Traffic Control Zones, developed by The American Traffic Safety Services Association

## 8.1. Selection Criteria

The following factors should be considered when selecting acceptable barrier systems:

- **Traffic speeds and vehicle mix.** The specified (or allowed) barrier systems should be matched to site characteristics. It is critical to use systems that match the crash testing level that is appropriate for each part of the work zone. For example, proprietary barriers are sometimes produced in TL1, TL2, and TL3 versions; although the test level designation is usually embossed on each barrier segment, at a distance they look very similar. While TL-3 barriers are the most frequently used, a TL-4 system could be appropriate for a site with large volumes of heavy trucks, such as a freeway that serves a major freight terminal, seaport, or heavy industrial site.
- **Available dynamic lateral deflection distance.** As discussed in Section 2.2 of this document, the specified (or allowed) barrier system(s) should be compatible with the available deflection space. An anchored system might be necessary in locations where there is little deflection space, such as bridges.
- **Expected crash frequency and severity.** In the event of a crash, all other things being equal a high-deflection system is generally more forgiving to vehicle occupants than a rigid system. This is especially important for locations where the crash would be at a high angle hit. For example, when barriers are installed perpendicular to the travelled way to block off a ramp, it is likely that an errant vehicle would hit the barrier head-on, which tends to produce greater injury than a sideswipe. Using a barrier system that deflects can partially mitigate head-on collision severity; providing a vehicle arresting net upstream of the barrier could be an even safer solution.
- **Work duration and stage changes.** Because of their portability, ballast filled barriers should be considered for maintenance operations and shorter-duration projects (or project stages) that would otherwise be unprotected. Specialty products such steel barriers with retractable wheels, moveable barrier systems, truck mounted mobile barrier systems, or vehicle arresting systems should be considered if the system needs to be moved frequently. An example would be projects where the barrier will be moved each night to give the contractor more workspace during off-peak hours and/or provide increased safety for workers. Other examples where the work operation is relatively short in length and time to complete, such as bridge inspections, pothole repair, joint repair, guardrail/barrier and terminal repair, or other short duration operations would provide safety and operational benefits if a mobile barrier system were used.
- **Installation and removal risks.** Workers who install, remove, and repair barriers often do so with limited protection. The amount of time needed to complete these tasks is a significant consideration, especially for high-volume, high speed roadways that remain open to traffic while setting and removing barriers. In general, steel and plastic barriers can be installed and removed more quickly than concrete barriers.
- **Site accessibility.** The use of water- or sand-filled plastic barriers should be considered for remote sites where it would be expensive or difficult to deliver steel or concrete barriers, including situations where heavy equipment for lifting concrete barriers is not readily available.
- **Compatibility.** Crashworthy permanent and temporary barriers are produced in several shapes, such as New Jersey barrier, F-shape barrier, single-slope barrier, and various

proprietary shapes. If the temporary barrier system will terminate at an existing permanent barrier, the shapes should be compatible to reduce the need for special hardware at the transition (even when the shapes match), and crash tested transition sections should be specified. In situations where the temporary positive protection system terminates in a clear zone, the crashworthy end treatment should be compatible with the barrier. Also, note that many different types of connectors are used for concrete barriers; they should not be intermixed within a single barrier run.

- **Contractor experience and project costs.** When the designer concludes that more than one barrier system can provide satisfactory performance, consider allowing the contractor to select the barrier system of their choice. This may be done by a note on the design plans and/or a specification/special provision in the contract. For example, the specifications could include a list of acceptable systems, or the designer could specify a preferred system and allow the contractor to propose alternates that provide equivalent performance. This can increase bid competitiveness and potentially reduce project costs.

## 8.2. Barrier Procurement and Specification

*While many agencies limit the number of designs in their agency design manuals for various reasons, there are no restrictions on the maximum or minimum number of systems a highway agency may allow, except to ensure federal-aid and highway agency procurement regulations are satisfied. In some cases, highway agencies might only allow one specific generic system for all their TCPB needs. The approved systems allowed by a highway agency might be based on collaboration with their highway contracting industry in order to maximize competition and obtain the lowest bid prices. Regardless, the ultimate decision on the system(s) allowed should be based on engineering experience and in-service performance.*

*All temporary FHWA accepted barrier systems in the U.S. can be re-used multiple times. Since the cost of purchasing a barrier system is typically passed through to highway agencies by contractors and other suppliers, it is important for agencies to strike a balance between innovation and standardization for barrier systems used on their projects. Contractors can reasonably be expected to wish to obtain the full useful life and value from a barrier system investment. Nevertheless, highway agencies should stay abreast of products and technologies to ensure that new barrier systems can be introduced if they offer the potential for improved public safety or long-term cost-savings. In some cases, a test deployment on a limited basis will offer the opportunity for the agency to try out a new system prior to widespread deployment.*

*Most agencies have a CADD library of standard detail drawings to assist their designers, project construction managers and staff, hardware manufacturers and suppliers, and contractors for efficiency and consistency in preparing and implementing TTC plans. For positive protection hardware, including TPCPs and terminals, it is critical for agencies prepare their standard detail drawings to reflect crash test conditions on the layout drawings and notes provided on the drawing plate(s). Agencies can help address this by assuring that CADD libraries used to develop plan sets include true-scale representations of positive protection devices and terminal hardware.*

*During TTC plan production, designers should assure the field conditions will be available for the standard detail drawing selected. Examples of important factors for designers to consider include:*

- Account for the actual width of the hardware and amount of shy distance from travel lanes in cross sections.*
- Lateral working width for positive protection hardware deflection is available.*
- Adequate space is available for crash tested terminals to perform as tested.*
- Surfaces the TPCPs will have to be placed on satisfy the structural adequacy for the crash test conditions.*

*If field conditions are not satisfactory for the standard detail drawing selected, alternatives should be designed. These may include using other positive protection hardware systems that will fit the field conditions; assuring anchoring techniques are specified, including contract pay items, if appropriate per agency policies; or designing temporary pavement to support TPCP to fit the standard detail drawing conditions, including contract pay items, if appropriate per agency policy.*

## 9. Review/Approval and Appeal Processes

Our agency has developed a systematic framework to review the need for positive protection. This process helps assure that decisions about the use (or non-use) of positive protection devices are made consistently throughout the agency, reflect the unique characteristics of each site, and incorporate the accumulated experience of designers and construction field engineers from our agency and our colleagues in other jurisdictions.

### 9.1. Review & Approval Process

As part of the TMP review process, each designer should prepare a memorandum (or form) that describes the decision to use (or not use) positive protection. *The memo should include the following elements:*

- Describe the general project including the scope of work.
- Describe the site characteristics, anticipated construction sequence and methods, and any site-specific issues.
- Identify and describe the alternatives that were evaluated.
- Indicate whether the decision to use (or not to use) positive protection was made based on the agency's mandatory criteria, based on quantitative engineering study, or based on engineering judgment.
- Discuss the decision factors used to select the preferred option.
- Clearly indicate whether any exceptions to agency policy are requested in connection with the decision to use (or not use) positive protection.

*Discuss or cross-reference the agency's approval process here, e.g., where to send documents, who can approve them, timelines, etc.*

### 9.2. Appeal Process

Occasionally there are disagreements about whether positive protection should (or should not) be used for a specific project. For example, a designer might think positive protection should be used at the site, while a plan checker feels it is not necessary. Our agency has established an appeal process that is intended to resolve these disputes promptly, amicably, and consistently.

*Describe the appeal process here, for example where to send appeals, who reviews them, timelines, etc. The appeal process could be patterned after other design approval and review processes already used successfully by the agency, such as a process for approving exceptions to design standards. If there are multiple appeal levels (e.g., at different levels of the organization) also explain them here.*

### 9.3. Constructability and/or Quality Control Plan Reviews

*Constructability and and/or quality control plan reviews of PS&Es are recommended good practices, including work zone traffic control plans and specifications. If these types of reviews are conducted by States, the inclusion of positive protection traffic control plan items discussed in Section 8.2 are recommended for inclusion in these reviews.*

## 10. Glossary of Terms

To facilitate communication and consistency, terms used in this publication are defined below and as illustrated in Figure 70. Individual agencies may develop and use their own definitions. Additional terms and definitions needed as part of the decision making process should be established for each highway agency guideline. In some cases, the definitions may be derived from terms used in national standards and guidance manuals, such as the Manual on Uniform Traffic Control Devices (MUTCD) [1] and AASHTO Roadside Design Guide (RDG)[12]. Numeric values used in definitions should be established independently by each agency based on relevant experience, professional judgment, and driver expectations. Threshold values may be formal highway agency policy decisions. A highway agency may choose to have different definitions for the same term based on project variables, such as type of improvement work; location of project, for example rural or urban; or type of facility, for example freeway or two-lane. It is important to assure consistency with values and terms used elsewhere in the state design manual.

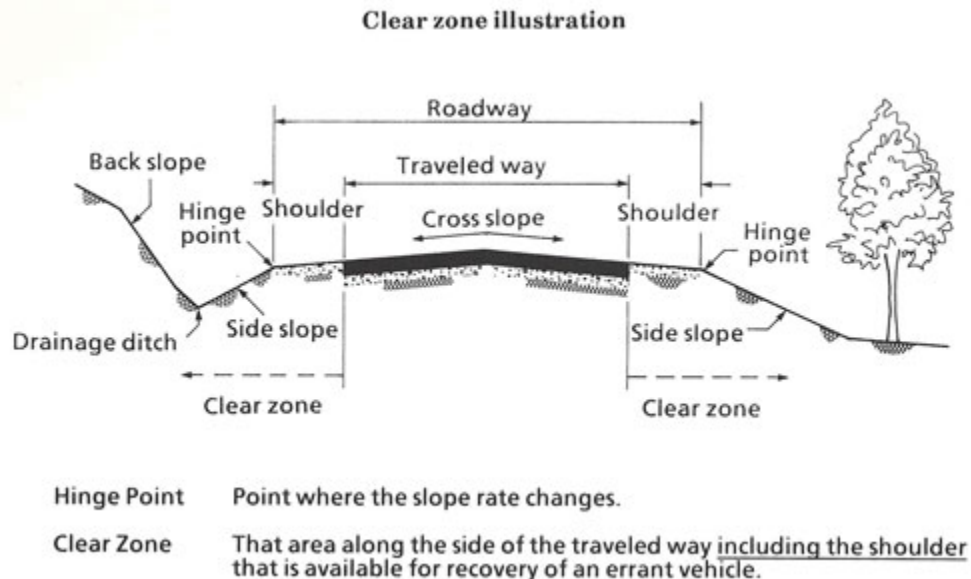

Figure 70. Illustration of several frequently used design terms.

Source: FHWA

- **Clear Zone:** The unobstructed, traversable area provided beyond the edge of the through traveled way for the recovery of errant vehicles. The clear zone includes shoulders, bicycle lanes, and auxiliary lanes, except those auxiliary lanes that function like through lanes [9].
- **Duration of Work:** Total work time at a specific location, from the first moment a worker is exposed to traffic, until the moment the work is completed, including time when workers might not be present.

- **Exposure Control Measures (ECMs):** Traffic management strategies to avoid work zone crashes involving workers and motorized traffic by eliminating or reducing traffic through the work zone, or diverting traffic away from the workspace.
- **High Speed:** Any roadway with a regulatory posted or statutory speed limit of 45 mph or greater.
- **High Volume:** *SHRP2 report #S2-R26-RR-2 (2011) provided the following definition of a high-volume roadway:* Traffic volume exceeding approximately 5000 vehicles per day for rural highways and 10,000 vehicles per day for urban highways. Table 8 provides an example of how this is calculated.

Table 8. Example of method for calculating “high” volume.

Environment	"High Volume" Threshold (vehicles per day)	Peak Hour Directional Split*	Portion of Daily Traffic Occurring During Peak Hour*	"High" Directional Hourly Volume
Rural	5,000	60/40	10.0%	300
Urban	10,000	60/40	7.5%	450
* Directional splits and peak hour percentages are always site-specific. Values shown here are for illustrative purposes only.				

- **Impact Attenuator:** A device designed to dissipate energy if a head-on collision occurs at the upstream end of a temporary traffic barrier system (also informally known as a crash cushion).
- **Long term duration:** The MUTCD defines “long term” as follows: Any duration of work that is expected to take 3 days or longer at a specific location [1].
- **Median crossover:** a temporary pavement that allows motorized traffic to be shifted laterally to the opposite side of a divided highway.
- **Pocketing:** A situation where an errant vehicle (or test vehicle) is captured by a less resistant portion of a barrier system, possibly resulting in vehicle rollover or unstable vehicle dynamics.
- **Positive Protection:** Devices that contain and/or redirect vehicles and meet the crashworthiness evaluation criteria contained in National Cooperative Highway Research Program (NCHRP) Report 350 [9] or American Association of State Highway and Transportation Officials (AASHTO) Manual for Assessing Safety Hardware (MASH) [8].
- **Snagging:** A situation where part of an errant vehicle or test vehicle (usually a corner) catches an uneven surface or protrusion, possibly tearing the vehicle’s sheet metal or causing unstable vehicle dynamics.
- **Temporary Traffic Barrier:** A temporary portable concrete barrier (TPCB), temporary steel barrier, sand-filled barrier, water-filled barrier, moveable concrete barrier, mobile barrier, or truck mounted attenuator that complies with agency standards or is included on the agency’s approved proprietary products list.
- **Traffic:** Motorized and non-motorized road users, excluding any construction or maintenance vehicles or equipment operated within the work space.

- **Vaulting:** A situation where an errant vehicle (or test vehicle) goes over the top of a barrier.
- **Work Zone Safety Management:** The entire range of traffic management and control and highway safety strategies and devices used to avoid crashes in work zones that can lead to worker and road user injuries and fatalities, including positive protection devices, exposure control measures, and other traffic control measures.

## 11. References

- [1] Federal Highway Administration, Manual on Uniform Traffic Control Devices, Washington, D.C., 2009. [2] Organization for Economic Co-operation and Development (OECD), "Towards Zero: Ambitious Road Safety Targets and the Safe System Approach," Paris, France, 2008.
- [3] Pegua, S.M., "An Analysis of Fatal Occupational Injuries at Road Construction Sites, 2003-2013," U.S. Department of Labor, Bureau of Labor Statistics <https://www.bls.gov/opub/mlr/2013/article/an-analysis-of-fatal-occupational-injuries-at-road-construction-sites-2003-2010.htm>, Washington, D.C., Nov 2013.
- [4] Tefft, B., "Impact Speed and a Pedestrian's Risk of Severe Injury or Death," AAA Foundation for Traffic Safety <https://aaaafoundation.org/impact-speed-pedestrians-risk-severe-injury-death/>, Washington, D.C., 2011.
- [5] National Highway Traffic Safety Administration, "Fatality Analysis Reporting System," <https://www.nhtsa.gov/research-data/fatality-analysis-reporting-system-fars.>, 2012.
- [6] Zibermintz, R., "I-35 Reopens After Tuesday Morning Crash," The Des Moines Register, 2014.
- [7] Ross Jr, H.E., Sicking, D.L., Zimmer, R.A. and Miche, J.D., "NCHRP-350 Recommended Procedures for the Safety Performance Evaluation of Highway Features," National Cooperative Highway Research Program, Transportation Research Board, Washington, D.C., 1993.
- [8] American Association of State Highway and Transportation Officials (AASHTO), "Manual for Assessing Safety Hardware.," Washington, D.C., 2009.
- [9] American Association of State Highway and Transportation Officials (AASHTO), "Manual for Assessing Safety Hardware," Washington, D.C., 2016.
- [10] American Association of State Highway and Transportation Officials (AASHTO), "Roadside Design Guide, 4th edition, Washington, D.C., 2011.
- [11] American Association of State Highway and Transportation Officials (AASHTO) and Federal Highway Administration (FHWA), "<https://design.transportation.org/wp-content/uploads/sites/21/2018/06/MASH-Implementation-Agreement-Final.pdf>," AASHTO/FHWA Joint Implementation Agreement for MASH 2016, Washington, D.C., December 2015.
- [12] Bielenberg, R.W., et al., Midwest Roadside Safety Facility (MwRSF), "Low Deflection Temporary Concrete Barrier System TPF-5(193) Supplement 88, Lincoln, Nebraska, 2014.
- [13] Lindsay Corporation, "Absorb 350 Crash Cushion System <http://www.barriersystemsinc.com/absorb-350-crash-cushion/>," Barrier Systems, Inc., 2003.

- [14] Wiebelhaus, M.J., et al., Midwest Roadside Safety Facility (MwRSF), "Development of a Temporary Concrete Barrier to Permanent Concrete Median Barrier Approach Transition" TRP-03-208-10, Lincoln, Nebraska, 2010.
- [15] Rosenbaugh, S.K. et al., Midwest Roadside Safety Facility (MwRSF), "Termination and Anchorage of Temporary Concrete Barriers", TRP-03-209-09, page 6," Lincoln, Nebraska, 2009.
- [16] Bielenberg, R.W., et al., "Testing and evaluation of MASH TL-3 transition between guardrail and portable concrete barriers" TRP-03-335-17, Lincoln, Nebraska, 2017.[17] Bielenberg, R.W., et al., Midwest Roadside Safety Facility (MwRSF), "Development of Tie-Down and Transition Systems for Temporary Concrete Barrier on Asphalt Road Surfaces," TRP-03-180-06, Lincoln, Nebraska, 2007.
- [18] Sheikh, N.M. and Menges, W.L., Texas A&M Transportation Institute, "Development and Testing of a Transition from Free Standing to Pinned Temporary Concrete Barrier", 405160-26," College Station, Texas, 2013.
- [19] American Road and Transportation Builders Association (ARTBA), "Guidelines on the Use of Low-Profile Portable Concrete Barrier in Low to Moderate Speed Work Zones", " Washington, D.C., 2015.
- [20] Mobile Barriers, LLC, "Mobile Barriers MBT-1," Available: <http://www.mobilebarriers.com>. [Accessed: 06-Aug-2014], 2014.
- [21] New Zealand Transport Agency (NZTA), "Code of Practice for Temporary Traffic Management Part 8 of the Traffic Control Devices Manual," <https://www.nzta.govt.nz/assets/resources/code-temp-traffic-management/docs/2018/section-b-equipment-copttm-4th-ed-nov2018.pdf>. page 77, Wellington, New Zealand, 2018.
- [22] Impact Absorption Inc., "Dragnet Work Zone Net Attenuator", <http://www.impactabsorption.com/dragnet-vehicle-arresting-barrier--vab-.html>, 2019.
- [23] American Road and Transportation Builders Association (ARTBA), Work Zone Safety Consortium "Guidance: Use of Work Zone Clear Zones, Buffer Spaces, and Positive Protection Distances", [https://www.workzonesafety.org/files/documents/training/courses\\_programs/rsa\\_program/RSP\\_Guidance\\_Documents\\_Download/RSP\\_Clear\\_Zones\\_Guidance.pdf](https://www.workzonesafety.org/files/documents/training/courses_programs/rsa_program/RSP_Guidance_Documents_Download/RSP_Clear_Zones_Guidance.pdf), 2014.
- [24] Federal Highway Administration, "Safety Edge", <https://www.fhwa.dot.gov/innovation/everydaycounts/edc-1/safetyedge.cfm>, 2012.
- [25] Ullman, G.L. and Iragavarapu, V., Texas A&M Transportation Institute, "Work Zone Positive Protection for Idaho," <http://itd.idaho.gov/highways/research/>, 2014.
- [26] Khattak, A. and Targa, F., "Injury severity and total harm in truck-involved work zone crashes Transportation Research Record. Transportation Research. Board, no. 1877, pp. 106–116, 2004," in Transportation Research Record Transportation Research. Board no. 1877, pp. 106–116, Washington, D.C., 2004.

Developed by:  
Traffic Operations and Safety Laboratory  
University of Wisconsin  
[www.topslab.wisc.edu](http://www.topslab.wisc.edu)



DEPARTMENT OF  
Civil and  
Environmental Engineering  
UNIVERSITY OF WISCONSIN-MADISON



**This material is based upon work supported by  
the Federal Highway Administration under  
Grant Agreement No. DTFH-61-14-H-00011**

Any opinions, findings, and conclusions or recommendations expressed in this publication are those of the author(s) and do not necessarily reflect the view of the Federal Highway Administration.